

INSTRUCTION MANUAL FT-707

YAESU MUSEN CO., LTD.

TOKYO JAPAN

YAESU ALL SOLID STATE HF SSB TRANSCEIVER FT-707



The FT-707 is an all solid state transceiver for the HF amateur bands. Featuring coverage of 80 through 10 meters, the FT-707 is designed for operation on SSB, CW and AM. Nominal power output is 100 watts on SSB and CW, and 50 watts on AM.

The extremely compact size of the FT-707 makes this model particularly well suited for mobile or vacation use. However, the advanced design techniques used in the FT-707 make it competitive with "top of the line" equipment of other manufacturers.

The receiver section includes a new and sophisticated front end, using a Schottky barrier diode ring module and carefully designed gain distribution, for excellent performance in the presence of strong signals. A very-low-noise premix local oscillator circuit is used, which further contributes to optimum receiver performance. Also included in the receiver is Yaesu's famous variable IF bandwidth, using two 8 pole IF filters, allowing continuously variable adjustment of the IF bandwidth, from 300 Hz to 2.4 kHz. Six pole filters of 600 Hz and 350 Hz bandwidth (-6 dB) are available for contest and DX operators, with selection of the SSB filter or CW filter available on the CW mode.

The transmitter side features two rugged bipolar transistors with multiple protection in the final amplifier stage, with individual low pass filter networks for each band providing excellent spectral purity.

Digital plus analog display of the operating frequency is provided. The front panel meter consists of a string of bright discrete LEDs, for easy monitoring of the received signal strength, relative power output, and the transmit ALC level.

Among the convenience features of your FT-707 are a high-performance noise blanker, VOX (with front panel controls), and receiver offset tuning.

Available options for the FT-707 include the FP-707 AC Power Supply, which provides the 13.5 volts DC required by the FT-707. The FP-707 provides outstanding regulation, for many years of trouble-free operation. Also available is the exciting FV-707DM external VFO, which provides twelve memory channels using a sophisticated synthesizer which allows scanning in 10 Hz steps and offset from memory channels. And for matching your antenna system to the 50 ohm impedance requirement of the FT-707, choose the FC-707 Antenna Coupler. All of the above accessories, plus a special mobile mounting bracket, are available from your Yaesu dealer.

We recommend that you read this manual in its entirety, so as to derive maximum benefit from your new FT-707, an exciting breakthrough from the communications experts . . . YAESU.

SPECIFICATIONS

GENERAL

Frequency coverage:

80 m	3.5–4.0 MHz
40 m	7.0–7.5 MHz
30 m	10.0–10.5 MHz
20 m	14.0–14.5 MHz
17 m	18.0–18.5 MHz
15 m	21.0–21.5 MHz
12 m	24.5–25.0 MHz
10 m	28.0–29.9 MHz

Modes of operation:

LSB, USB, CW, and AM

Power requirements:

13.5 volts DC, negative ground

Current consumption:

DC 1.5 amps receive
DC 20 amps transmit

Case size:

93 (H) x 240 (W) x 295 (D) mm incl. heat sink

Weight:

Approx. 6.5 kg

TRANSMITTER

Power input:

SSB/CW	240 watts DC
AM	80 watts DC

Carrier suppression:

Better than 40 dB

Unwanted sideband suppression:

Better than 50 dB at 14 MHz, 1 kHz mod.

Spurious emissions:

At least 50 dB down

Frequency response:

350–2700 Hz (–6 dB)

Third order distortion products:

At least 31 dB down

Frequency stability:

Less than 300 Hz drift over 30 minutes after
10 minute warmup; less than 100 Hz drift
after 30 minute warmup

RECEIVER

Sensitivity:

SSB/CW	0.25 μ V for 10 dB S/N
AM	1.0 μ V for 10 dB S/N

Selectivity:

SSB	2.4 kHz (–6 dB); 4.0 kHz (–60 dB)
CW*	0.6 kHz (–6 dB), 1.2 kHz (–60 dB)
CW**	350 Hz (–6 dB), 1.2 kHz (–60 dB)
AM	3.6 kHz (–6 dB), 6.8 kHz (–60 dB)

Image rejection:

60 dB (80–12 m)
50 dB (10 m)

Audio output impedance:

4–16 ohms

Audio output:

3 watts @ 4 ohms @ 10% THD

Variable bandwidth control:

Continuous from 300 Hz to 2.4 kHz (SSB/CW
modes only)

Modulation type:

(SSB) Balanced modulator
(AM) Amplitude modulation of a low power
stage

Antenna output impedance:

50 ohms

Microphone impedance:

500–600 ohms (low impedance)

* with optional 600 Hz CW filter

** with optional 350 Hz CW filter

SEMICONDUCTORS

Transistors:

2SA496Y	1
2SA733A-P	2
2SA733A-Q	4
2SA952L	13
2SC380TM-Y	12
2SC535A	1
2SC732TM-GR	1
2SC1583G	2
2SC1589	2
2SC1674L	1
2SC1815GR	3
2SC1815Y	29
2SC1923R	2
2SC1959Y	3
2SC2290	2
2SC2395	2
2SC2407	2
2SD235Y	1
2SD592Q	1
2SD880Y	1
2N4427	1
MPS-A13	1

Field Effect Transistors:

2SK19TM-GR	5
2SK30A-Y	1
3SK73GR	7
J310	1

Integrated Circuits (IC):

SN76514N	1
μ PC2002V	1
μ PA54H	1
AN6552	1
F4024	1
MSM9520RS	1
TA7612AP	1
78L08	3
μ PC14305	1
μ PC14308	1
ND487C2-3R	1

Germanium Diode:

1N60	26
1S1007	14

Silicon Diodes:

10D1	14
10D10	4
1S1555	66
1SS53	37

Schottky Barrier Diode:

1SS16	6
-------	---

Zener Diode:

YZ-033	1
--------	---

Varactor Diodes:

1S2209	1
1S2236	1
FC63	1

Light Emitting Diodes:

GD4-203SRD	1
TLG205	5
TLR205	2
TLY205	3

LED Display:

5082-7623	6
-----------	---

Specifications subject to change without notice.

ACCESSORIES

The following accessories are included with your FT-707.

DC Power Cord	1
DC Fuse (20A)	1

FRONT PANEL CONTROLS AND SWITCHES

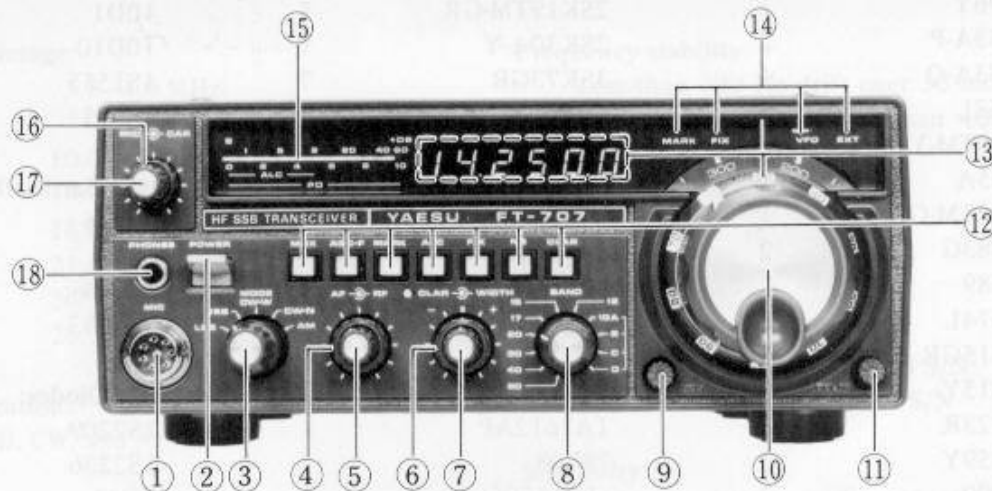

(1) MIC

The microphone jack accepts the microphone input line, push to talk (PTT) control, and scanner control lines (scanner requires optional FV-707DM).

(2) POWER

This is the main power on/off switch for the transceiver.

(3) MODE

This switch selects the desired mode: LSB, USB, CW-W (using SSB filters), CW-N (using optional 600 Hz or 350 Hz filter), or AM.

(4) RF GAIN

This control varies the gain of the receiver RF and IF stages. Clockwise rotation increases the gain level.

(5) AF GAIN

This control varies the gain of the audio amplifier stage. Clockwise rotation increases the AF volume level.

(6) WIDTH

The WIDTH control varies the IF passband from 2.4 kHz down to approximately 300 Hz (-6 dB).

(7) CLAR

This control allows offset from the VFO frequency of approximately ± 3 kHz on receive, when the front panel CLAR switch is pushed.

(8) BAND

This switch selects the desired band.

(9) VOX GAIN

This control varies the sensitivity of the VOX (voice operated T/R control) system.

(10) MAIN TUNING KNOB

This knob drives the main tuning variable capacitor, for control of the operating frequency.

(11) DELAY

This control provides adjustment of the VOX relay hang time. It may be set for your individual requirements for CW or SSB operation.

(12) SELECT switches

MOX This switch selects manual activation of the transmitter. Push the switch once to close the PTT circuit, and again to allow receiver recovery.

AGC F Push this switch to select fast recovery time for the receiver AGC (Automatic Gain Control) circuitry. When this button is not pushed, slow AGC recovery will be selected.

MARK Push this button to activate the crystal calibrator (marker) circuit. The calibrator signal will be heard every 25 kHz.

ALC This switch checks the ALC level by the LED meter. When this button is not

pushed, the LED meter indicates TX relative power output (PO).

- FIX This switch to operate on fixed channel.
- NB This button activates the noise blanker circuit.
- CLAR Push this button to activate the receiver offset tuning (clarifier) feature.

(13) DIAL

The main tuning dial is calibrated every 50 kHz, with dial skirt markings every 1 kHz, for precise frequency determination.

(14) INDICATOR LEDs

These LED indicators provide visual reminders of calibrator, fixed channel (using an optional crystal), VFO, or external VFO operation.

(15) LEVEL METER

A string of colored LEDs provides visual indication of the received signal strength, relative power output, and the transmitter ALC level.

(16) CAR

The carrier control adjusts the CW or AM carrier level.

(17) MIC GAIN

This control varies the gain of the microphone amplifier stage during SSB or AM operation.

(18) PHONES

This is a standard phone plug for connection of your station headphones. The impedance is 8 ohms.

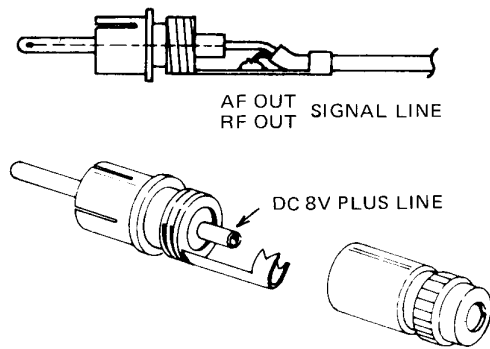

Pin plug

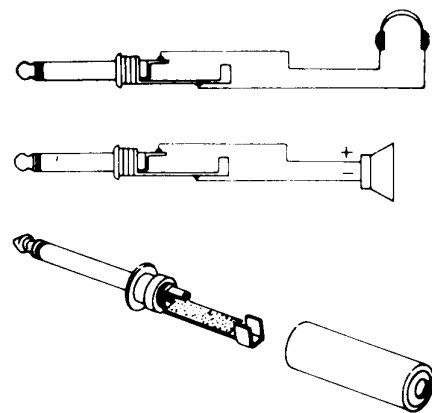

Headphone and external speaker connections

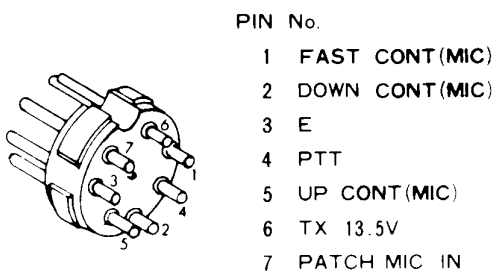

ACC Plug

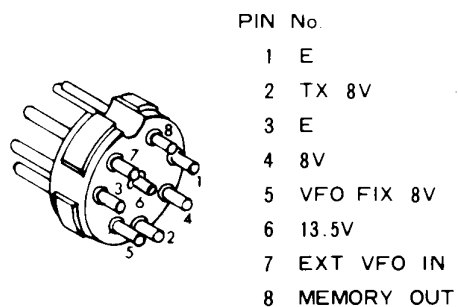

EXT VFO Plug

REAR PANEL CONNECTIONS

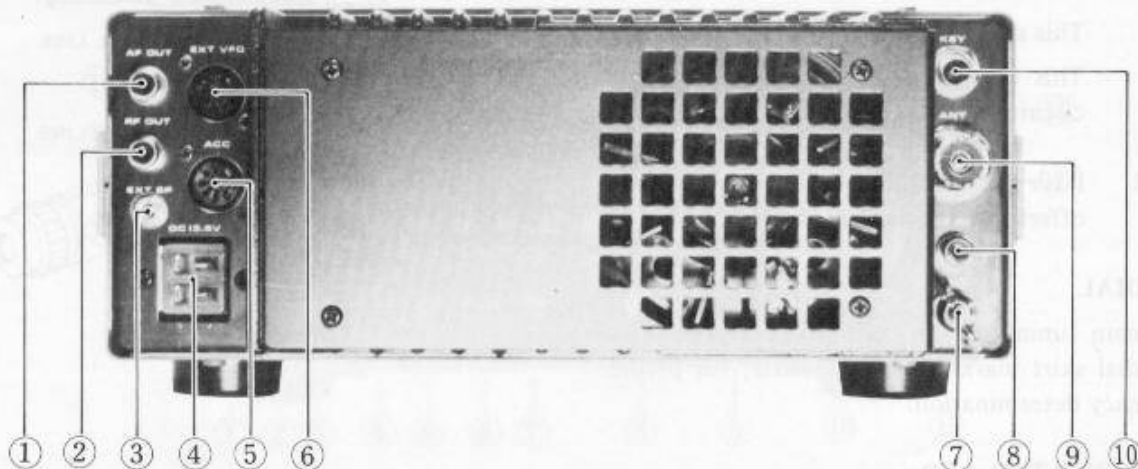

(1) AF OUT

This is an audio output jack which provides approximately 200 mV of audio output (before the AF GAIN control) for use with a tape recorder, etc.

(2) RF OUT

This is a low level signal frequency output jack for use with a transverter. The output is at 50 ohms impedance, at a level of 220 mV.

(3) EXT SP

This is a jack for connection to your station's external speaker. The FT-707 internal speaker will be cut off when a plug is inserted into this jack. The audio output impedance is 8 ohms.

(4) DC 13.5V

Connect this jack only to a DC supply of 13.5 volts, negative ground. Never connect AC power directly to this jack.

(5) ACC

The accessory plug accepts microphone input and PTT control lines, while providing connections to the output scanning control lines and the transmitter TX 13.5V line.

(6) EXT VFO

This jack provides connections to the FV-707DM External VFO.

(7) GND

Connect a good earth ground at this point.

(8) DC 8V

This jack provides an output of 8 volts DC for use with the FC-707 Antenna Coupler. The 8 volt line provides power for the FC-707 panel lamps.

(9) ANT

This is a standard UHF connector for connection to the station antenna system.

(10) KEY

Connect your CW key at this jack.

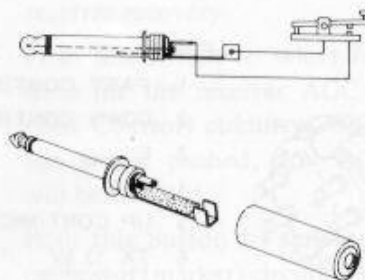

Key plug connections

MICROPHONE CONNECTIONS



YM-34

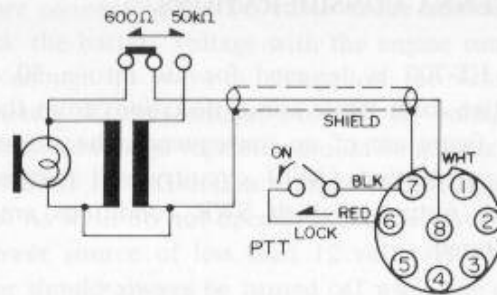

YM-34 MICROPHONE CONNECTIONS



YM-35

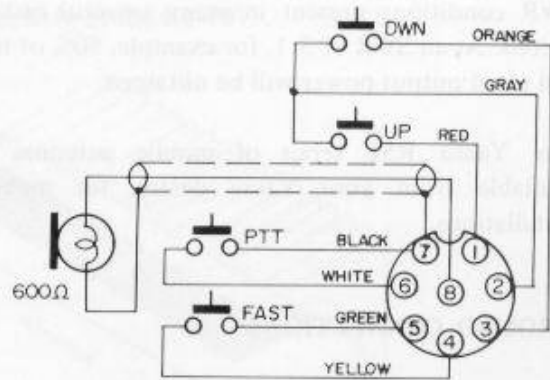

YM-35 MICROPHONE CONNECTIONS



YM-36

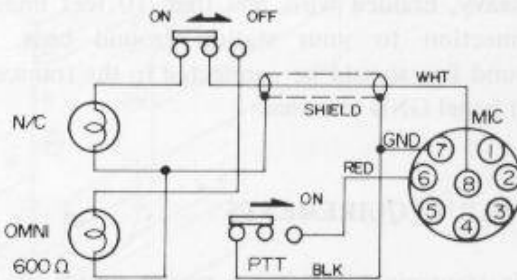

YM-36 MICROPHONE CONNECTIONS



YM-37

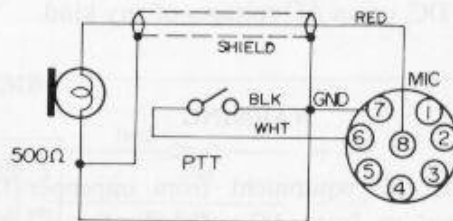

YM-37 MICROPHONE CONNECTIONS

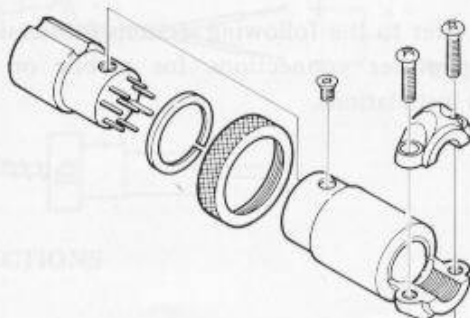

INSTALLATION

ANTENNA CONSIDERATIONS

The FT-707 is designed for use into a 50 ohm resistive load. While minor deviations from the 50 ohm figure are of no consequence, the automatic final protection (AFP) circuitry will reduce the power output if high SWR conditions are encountered.

However, your FT-707 AFP circuitry and final amplifier components are tolerant of the minor SWR conditions present in many amateur installations. At an SWR of 3:1, for example, 50% of the full rated output power will be obtained.

The Yaesu RSL series of mobile antennas is available from your Yaesu dealer, for mobile installations.

GROUND CONNECTIONS

This transceiver should be connected to a good earth ground for best performance and safety. Use a heavy, braided wire, less than 10 feet line, for connection to your station ground buss. The ground line should be connected to the transceiver rear panel GND terminal.

POWER REQUIREMENTS

This transceiver requires a power source of 13.5 volts DC, negative ground, at 20 amps on voice peaks. It is not possible to use this transceiver on 24 volts DC, or on AC voltages of any kind.

WARNING

Use of this equipment from improper DC voltages, or from AC voltages of any kind, will void the warranty on this equipment.

Please refer to the following sections for details on making power connections for mobile or base station installations.

FUSE REQUIREMENTS

A 20 amp DC fuse is located in the DC cable for this equipment. When changing fuses, be absolutely certain to use a fuse of the proper rating.

WARNING

Our warranty does not cover damage caused by use of an improper fuse.

MOBILE INSTALLATION

The DC cable for mobile installations is included with your transceiver.

Four under-dash mounting, a special mobile mounting bracket is available from your Yaesu dealer. This bracket, known as the MMB-2, allows installation of the FT-707 alone, or it may be adjusted to allow installation of the FT-707 and FV-707DM, or the FT-707 and FC-707 (the FC-707 and FV-707 may also be installed together, if desired).

The FT-707 should be mounted where there is adequate space around the heat sink to allow free circulation of air. Allow a space of about 20 cm behind and around the heat sink, and do not position the transceiver directly in the path of the heater ducts.

When making battery connections, it is absolutely essential that the proper polarity of the power cord be observed.

WARNING

Permanent damage will result if reversed-polarity supply voltage is applied to this transceiver. Our warranty does not cover damage caused by reversed power supply connections.

It is recommended that power connections be made directly to the battery instead of to the ignition switch. The battery provides considerable filtering against ignition noise, while connection to the ignition switch can place the FT-707 in a noise-producing circuit. The power lead must be kept as short as possible, and you should keep the lead away from ignition cables as much as possible.

When making battery connections, be certain to connect the RED power cable lead to the POSITIVE (+) battery terminal, and connect the BLACK lead to the NEGATIVE (-) terminal.

Before connecting the DC cable to the transceiver, check the battery voltage with the engine running fast enough to show a charge on the vehicle's ammeter. If the voltage exceeds 15 volts, the automobile voltage regulator should be adjusted, so as to limit the maximum voltage to less than 15 volts. As well, do not operate this transceiver from a power source of less than 12 volts. The transceiver should always be turned off when the car is started, to prevent transients in the automobile electrical system from damaging the transistor circuitry of the FT-707.

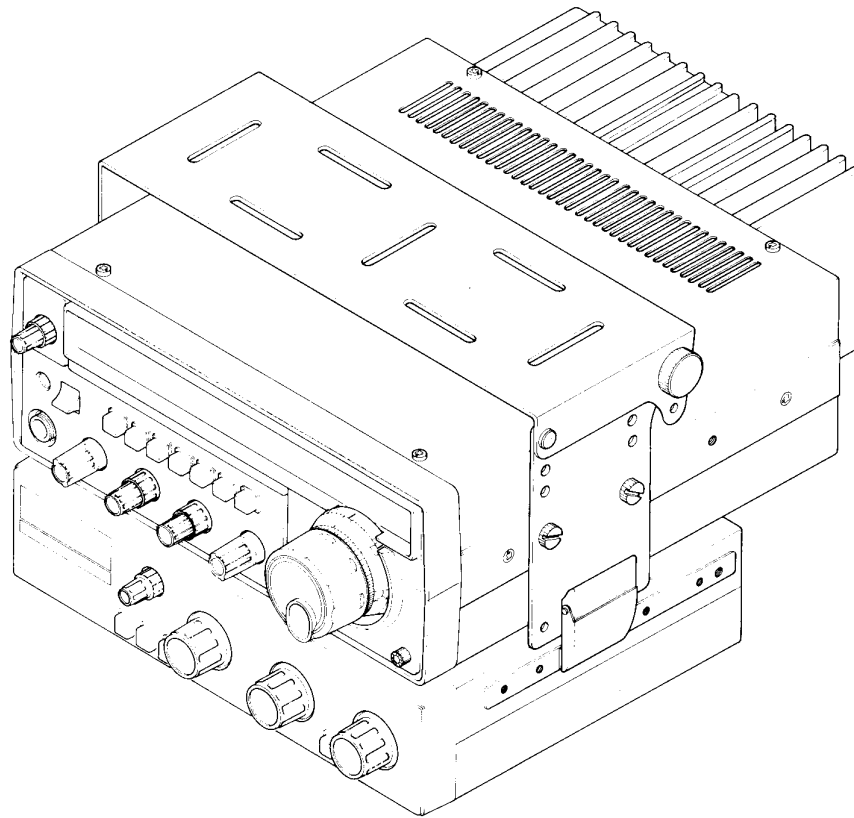

FT-707/FC-707/MMB-2

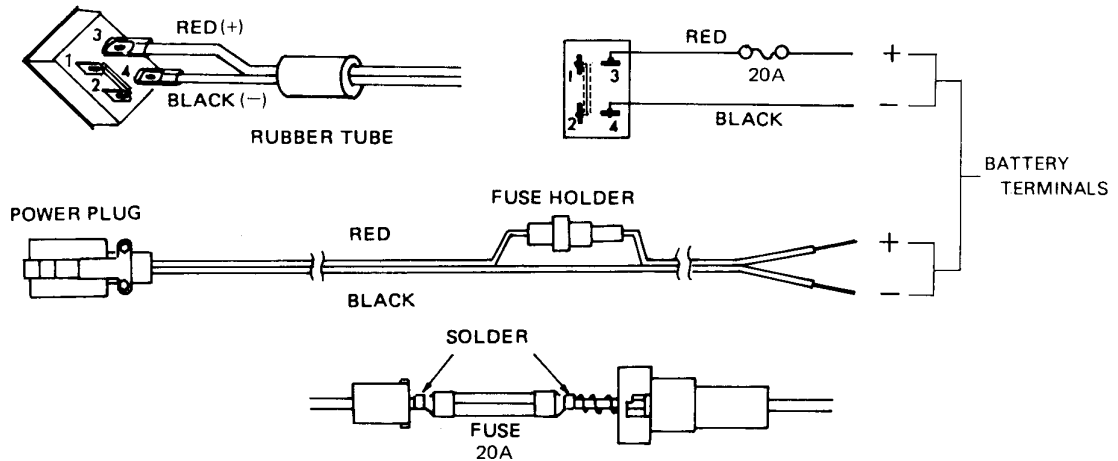

POWER CORD CONNECTIONS

BASE STATION INSTALLATION

The FP-707 AC Power Supply is expressly designed for your FT-707 transceiver, allowing operation from AC power sources of 100/110/117/200/220/234 volts, 50/60 Hz.

Before attempting operation of the FP-707 from AC mains, check to see that the voltage specification on the rear panel of the power supply matches your local supply voltage. This inspection must be made before applying power to this equipment.

WARNING

Operation of the FT-707 directly from AC mains, or operation of the FP-707 from improper supply voltages, or use of an improper fuse in either model, shall void the warranty.

Please refer to the power transformer primary connection chart for details of the proper connections inside the FT-707.

An AC fuse is located on the rear panel of the FP-707. For AC 100/110/117 volts, use only a 6 amp fuse. For 200/220/234 volts AC, use only a 3 amp fuse.

Once the power transformer and fuse inspections have been duly completed, connect the AC cable of the FP-707 to the wall outlet. Insert the DC plug from the FP-707 into the FT-707 DC 13.5V jack on the rear panel of the transceiver.

Connect a 50 ohm antenna or dummy load to the rear panel ANT jack.

Connect your station headphones, if used, to the front panel PHONES jack. Insertion of a plug into this jack automatically cuts off the internal speaker.

If you are using an external speaker, its plug may be connected to the rear panel SP jack. Insertion of a plug into this jack also cuts off the internal speaker. If headphones are used, insertion of the headphone plug into the front panel jack will cut off the external speaker, as well as the internal speaker.

If you are using a footswitch for PTT control, the lead from the footswitch may be connected to pin 6 of the rear panel ACC jack. Use pin 7 for the common connection.

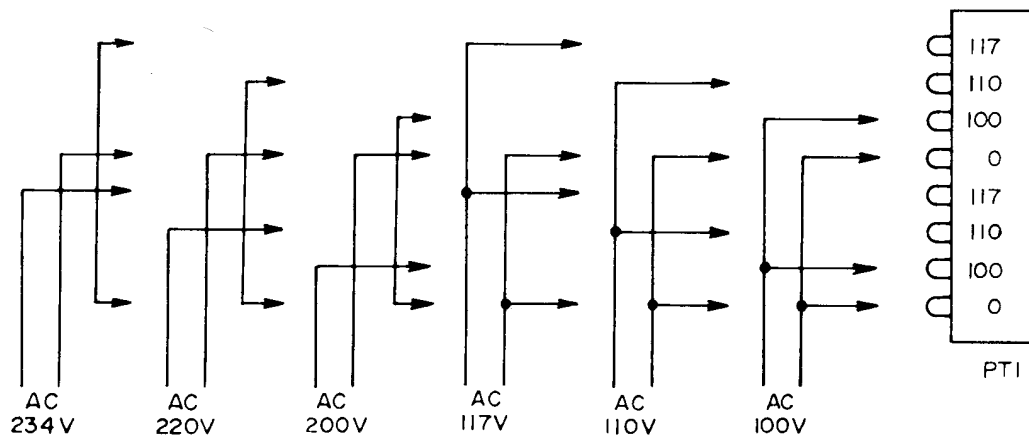

FP-707 POWER TRANSFORMER PRIMARY CONNECTIONS



FP-707/FT-707/YM-35/FC-707/FV-707DM

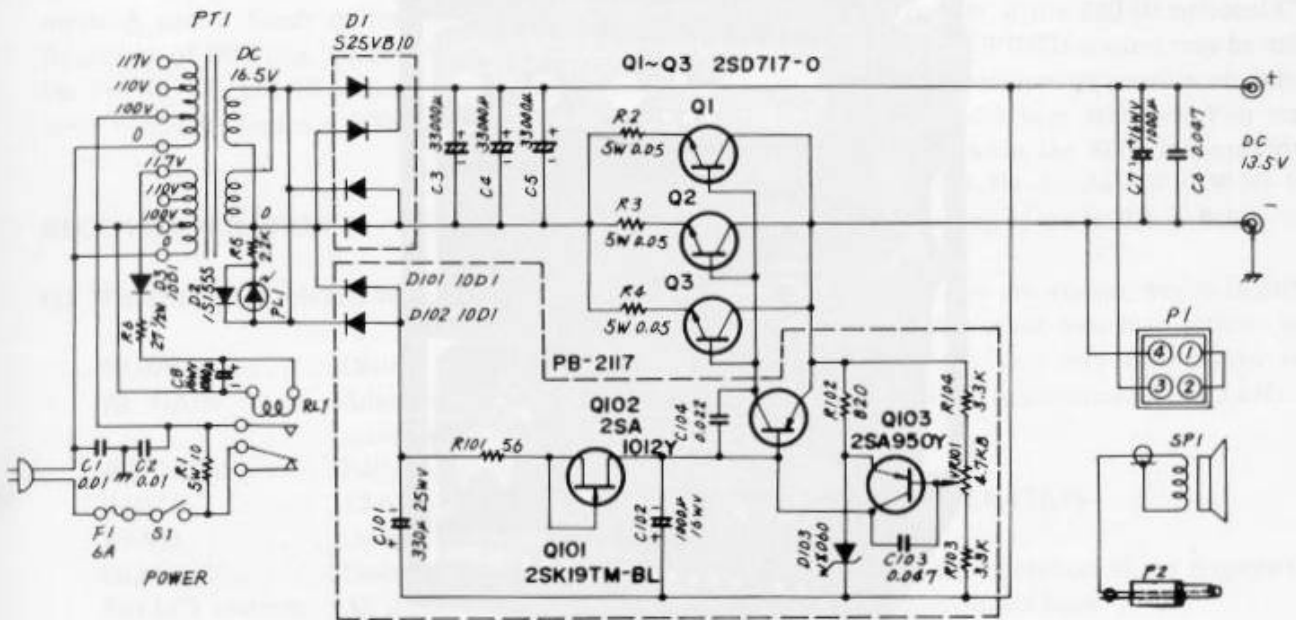

**FP-707
CIRCUIT DIAGRAM**

FP-707 CIRCUIT DIAGRAM

INTERCONNECTIONS

BASE STATION INSTALLATION

The FP-707 AC Power Supply is used to power the FT-707 transmitter, allowing operation from AC power sources of 100V, 120V, 220V, or 240 volts 50/60 Hz.

Once the power requirements and interconnections have been fully completed, connect the AC cord of the FP-707 to the wall outlet. Connect the DC plug from the FP-707 with the FT-707 DC 13.5V jack on the rear panel of the transmitter.

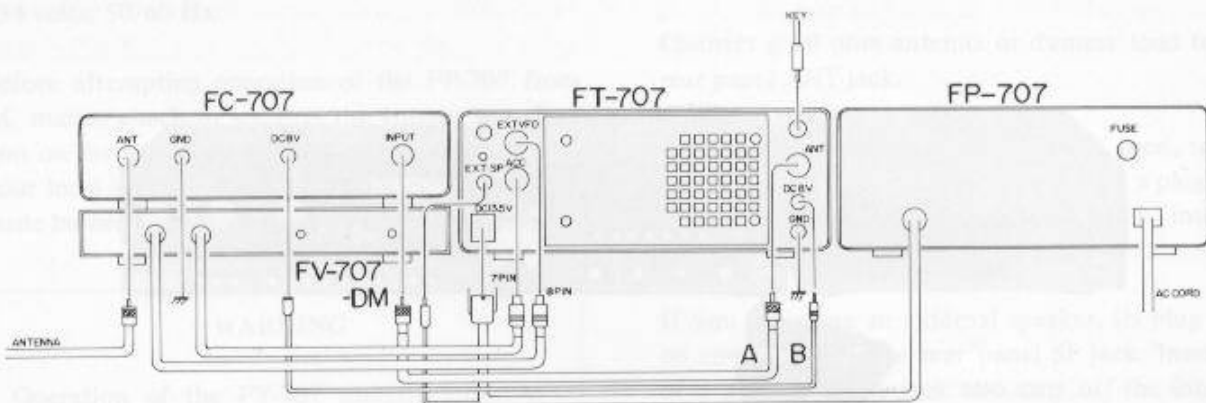

Operation of the FT-707 is described in the manual. On reception of the SP, the speaker will produce a signal. The speaker will produce a signal when the front panel jack will be connected to the speaker.

Connect the antenna or antenna lead to the ANT jack. Connect the speaker to the speaker jack. Connect the speaker to the speaker jack. Connect the speaker to the speaker jack. Connect the speaker to the speaker jack.



FC-707/FP-707/FT-707/FV-707DM/YM-35

OPERATION

The all solid state design of the FT-707 means that tuning procedures are minimal. However, care should be exercised in operation to ensure that spurious signals are not generated by an improperly-adjusted transmitter. The following paragraphs will describe the tuning procedure for receiver and transmitter operation.

INITIAL CHECK

Before turning the transceiver on, confirm once again that all interconnections, power supply voltages, and fuses are correct.

FREQUENCY DETERMINATION

Frequency display on the FT-707 is by means of digital as well as analog display. The digital display is a true frequency counter, so no recalibration is required when changing bands.

The analog display may be aligned by direct comparison to the digital display. Note that the lower band edge of the 40, 30, 20, 17, 15, and 10 meter A and C bands corresponds to a starting frequency of 000 (e.g. 14.000 MHz) on the dial. On the 80, 12, and 10 meter B and D bands, the lower band edge begins at 500 (e.g. 3.500 MHz).

RECEIVE OPERATION

(1) Preset the controls and switches as follows:

MODE Desired mode
AF GAIN Adjust subsequently for a comfortable level
RF GAIN Fully clockwise
WIDTH 12 o'clock position
BAND Desired band
DIAL Desired frequency
SELECT switches . All should be off initially

(2) Be certain that a 50 ohm antenna or dummy load is connected to the antenna jack.

(3) Set the transceiver POWER switch to ON. If you are using the FP-707 AC Power Supply, slip the FP-707 power switch on first, then turn on the transceiver.

(4) Adjust the AF GAIN control for a comfortable volume level. The frequency will be displayed on the digital display, and you may adjust the main dial for the desired operating frequency. Note that all receiver preselector networks are preset for each band, and no adjustment is required for peak performance.

(5) When pulse-type noise is encountered, push the NB (Noise Blanker) switch. While no noise blanker will eliminate all types of noise (such as atmospheric or cosmic noise), the FT-707 noise blanker is a state-of-the-art design which should effectively eliminate most types of automotive ignition noise.

(6) The WIDTH control may be used to adjust the width of the IF passband. In the receiver IF, two 8 pole SSB filters are used. The signal frequency at one of the filters is varied, using a mixing technique that produces no change in the beat tone of the incoming signal.

The WIDTH control is especially useful in eliminating high-pitched "buckshot" on SSB, but it may also be used effectively on CW as well: for example, if the 350 Hz optional CW filter is used, the WIDTH control may be used in the CW-W position to provide an intermediate bandwidth (e.g. 800 Hz). You may then switch between the 800 Hz bandwidth (CW-W) or 350 Hz bandwidth (CW-N) by appropriate setting of the MODE switch.

(7) If the station you are working begins to drift, push the CLAR select switch to activate the clarifier control. You may then follow the drifting signal, up to a maximum of ± 3 kHz.

TRANSMITTER OPERATION

The discussion of the operation of the transmitter will be on a mode-by-mode basis.

It is important that an antenna or 50 ohm dummy load be connected to the antenna jack at all times.

Never switch any of the front panel switches (BAND, MODE, SELECT, etc.) while transmitting. It is possible to damage this equipment by ignoring this simple precaution.

Never transmit “key down” for more than 30 seconds at a time. If you transmit for 30 seconds, we recommend a rest period of at least two minutes before the next transmission. The final amplifier contains a heat sensing protection system, which will reduce the power output if the temperature of the final transistors becomes too high.

SSB MODE

- (1) Preset the controls and switches as follows:

MODE Desired mode, LSB or USB
ALC ON (switch pushed)
MIC GAIN . . Set to the 10 o'clock position
CAR Fully counterclockwise

- (2) Close the microphone PTT switch.
- (3) Speak in a normal voice into the microphone, and note the reading on the level meter. On voice peaks, the ALC indication should not illuminate any of the yellow LEDs. If the LEDs become consistently illuminated, retard the setting of the MIC GAIN control.
- (4) If you push the ALC switch again, the relative PO meter will be activated. In this case, 5 LEDs should become illuminated on voice peaks.
- (5) Release the PTT switch for receiver recovery.
- (6) For VOX operation, advance the front panel VOX control until your voice activates the transmitter (PTT switch released). You may then adjust the front panel DELAY control to obtain the desired relay hang time. If the speaker output activates the VOX, you may have the VOX control advanced too far. Otherwise, the ANTITRIP control inside the cabinet may require adjustment; see the “Maintenance and Alignment” section of this manual for details.

CW MODE

- (1) Set the MODE switch to CW-W or CW-N, and set the VOX control fully counterclockwise. Insert your key lead into the rear panel KEY jack.

- (2) Push the front panel MOX switch (or close your footswitch, if used), and close your key. The sidetone will be heard in the speaker. Advance the CAR control until the desired power level is obtained. Maximum power output occurs when 8 LEDs are lit up.
- (3) To adjust the CW semi-break-in circuit, advance the VOX control so that the CW sidetone activates the transmitter when you close your key. Adjust the DELAY control to provide the desired relay hang time.
- (4) For QRP operation, the CAR control will provide adjustment of the power output level, down to 10 watts. An in-line wattmeter may be used for precise power measurement.
- (5) When the 600 Hz or 350 Hz CW filter is installed, set the MODE switch to CW-N (narrow) to select the 6 pole CW filter. When the MODE switch is set to CW-W, the SSB filter will be selected. As noted earlier in this chapter, it is possible to use the WIDTH control to good advantage in providing a variety of bandwidths in the CW-W position.

AM MODE

- (1) Set the MODE switch to AM, the ALC switch OFF, and rotate the MIC GAIN and CAR controls fully counterclockwise.
- (2) Close the PTT switch, and advance the CAR control until 4 LEDs light up.
- (3) Set the ALC switch ON, and speak into the microphone in a normal voice, and advance the MIC GAIN control until the first LED lights up dimly.

CW FILTER INSTALLATION

- (1) Refer to Figure 1, and remove the top cover of the transceiver.
- (2) Refer to Figure 2, and remove the two screws marked "A" in the drawing. Remove the RF Unit.
- (3) Refer to Figure 3, and remove the four screws marked "B" restraining the IF Unit. Remove the three connectors of the IF Unit, and remove the board from the transceiver.
- (4) Mount the CW filter in the position shown in Figure 4. Cut the two jumpers shown in the drawing when the CW filter is installed.
- (5) Replace the IF Unit and RF Unit into the transceiver. Replace the top cover of the transceiver. Installation is now complete. The CW filter will be selected when the MODE switch is set to CW-N, while the SSB filter will be selected when the MODE switch is set to CW-W.

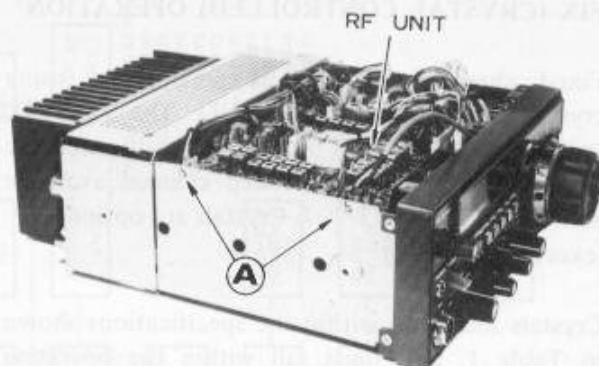

Fig. 2

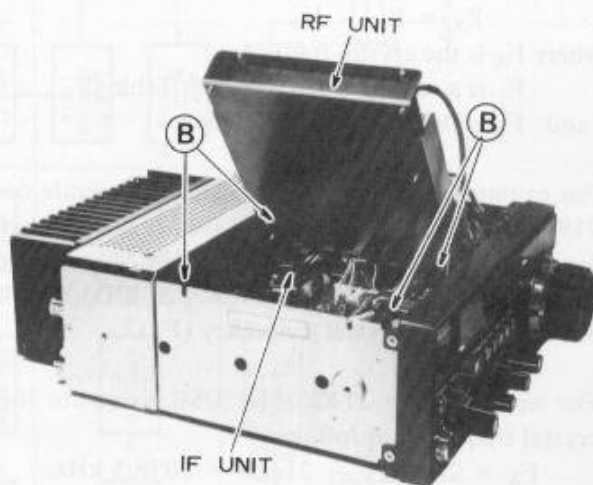

Fig. 3

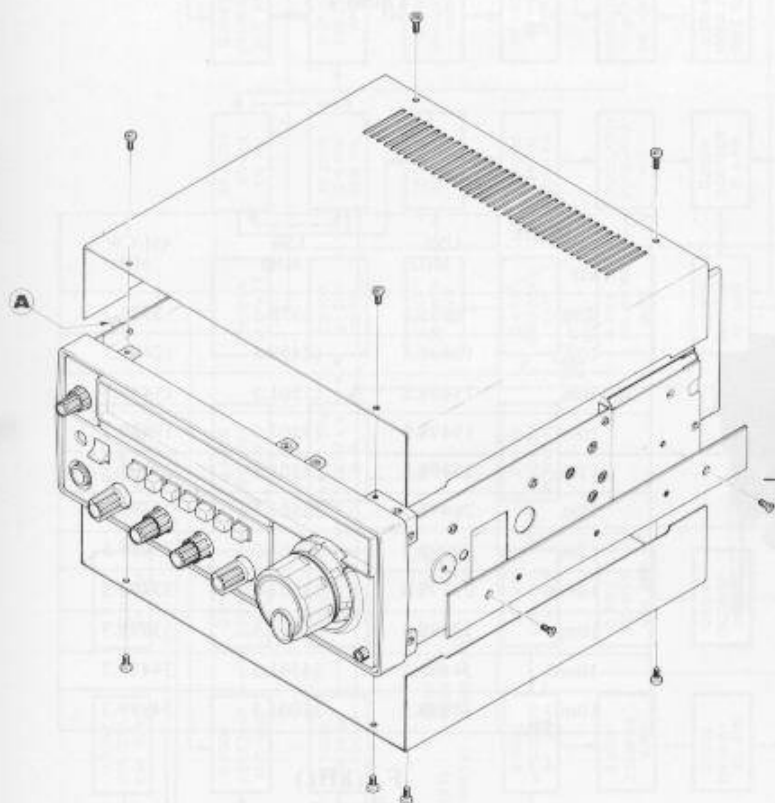

Fig. 1

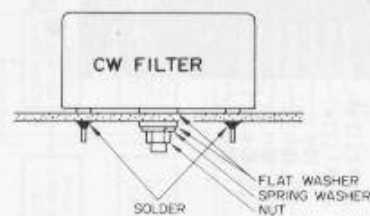
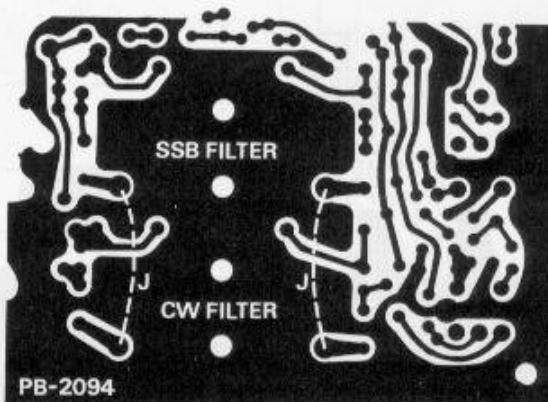

Fig. 4

FIX (CRYSTAL CONTROLLED) OPERATION

Fixed channel operation is possible by using crystals installed in the AF UNIT. The VFO/FIX switch must be placed in the FIX position. There is only one crystal controlled channel available per band with the FT-707. Crystals are optional. (except 30m band)

Crystals must fall within the specifications shown in Table 1, and must fall within the operating range 5.5–5.0 MHz. Frequency calculation for the crystals is made from the formula

$$F_X = F_1 - F_O$$

where F_X is the crystal frequency,

F_1 is a constant derived from Table 2.

and F_O is the operating frequency.

For example, let us say it is desired to operate on 7199 kHz LSB. Referring to Table 2, we see that for 40 meter LSB, F_1 is 12498.5 kHz. Subtracting F_O (7199 kHz) from F_1 (12498.5 kHz) yields 5299.5 kHz, the crystal frequency (F_X).

For operation on 21420 kHz USB, compute the crystal frequency as follows:

$$F_X = 26498.5 - 21420 = 5078.5 \text{ kHz.}$$

Inspection of the values of F_1 in Table 1 will reveal that the 7199 kHz crystal for LSB will work on 14202 kHz, 21202 kHz, etc. Of course, LSB is not normally used on these bands. If the operator switches to USB, the operating frequency will be moved 3 kHz (in this case, to 14199 kHz, 21199 kHz, etc.). If the move is made from LSB to CW, the frequency will move 2.2 kHz down. (to 7196.8, 14199.8, etc.)

To net the crystal on frequency when using the FT-707, use the transceiver digital display to adjust the trimmers for each crystal (TC₃₀₀₅ for 80 m, TC₃₀₀₆ for 40 m, etc.). Be sure that the CLAR switch is turned off during trimmer adjustment.

The optional crystals are available from your Yaesu dealer.

Holder	HC-25/U
Load C	30pF
Effective R	25Ω
Drive level	5mW

Table 1

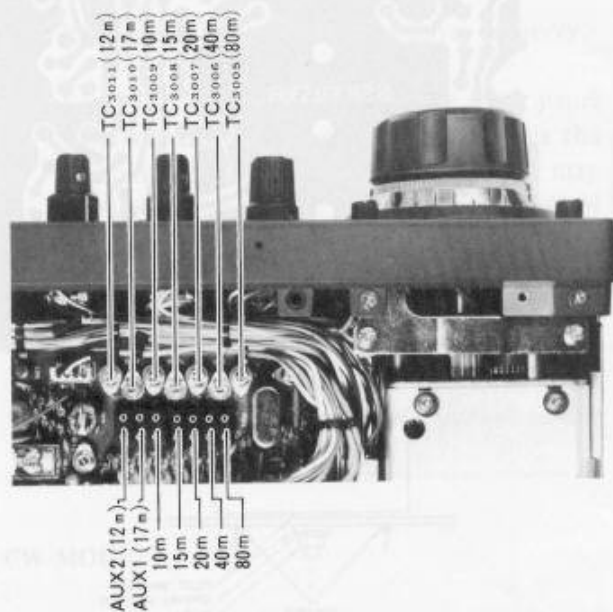

MODE BAND	USB MHz	LSB MHz	AM/CW MHz
80m	8995.5	8998.5	8996.3
40m	12495.5	12498.5	12496.3
※ 30m	15498.5	15501.5	15499.3
20m	19498.5	19501.5	19499.3
17m	23498.5	23501.5	23501.5
15m	26498.5	26501.5	26499.3
12m	29998.5	30001.5	29999.3
10mA	33498.5	33501.5	33499.3
10mB	33998.5	34001.5	33999.3
10mC	34498.5	34501.5	34499.3
10mD	34998.5	35001.5	34999.3

F_1 (kHz)

Table 2

CIRCUIT DESCRIPTION

The block diagram, and circuit description to follow, will provide you with a better understanding of this transceiver. Please refer to the schematic diagram for specific component details.

RECEIVER

The RF input signal from the antenna is fed through relay RL₄₀₀₁ (LPF Unit), lamp fuse F₄₈₀₁ (FAN MOTOR Unit), and passed through a high-pass filter of $f_c = 1.7$ MHz on the FAN MOTOR Unit. The signal is then delivered to pin 1 of J₁₀₀₂ on the RF Unit.

The signal is passed through individual antenna coils for each band and a 9 MHz trap, and amplified by Q₁₀₀₁ (3SK73GR), a dual gate MOS FET with excellent rejection of cross modulation and intermodulation. The amplified signal is fed through diode switched bandpass filter networks, which protect the mixer from out-of-band signals.

The RF signal is fed to the Schottky barrier diode ring module, Q₁₀₀₈ (ND487C2-3R), where the RF signal is mixed with a local signal delivered from Q₁₀₁₂ (2SC2407), resulting in a first IF of 8.9875 MHz. The input and output of the diode ring are protected by 50 ohm attenuators, which stabilize the input and output terminations for optimum intercept characteristics. The IF signal is then amplified by mixer post-amp Q₁₀₀₉ (2SC2407) and fed to pin 5 of J₁₀₀₁ for delivery to the IF Unit.

The local signal for the mixer is derived in the following manner: the incoming VFO signal from the VFO Unit is mixed with a crystal controlled local signal from the AF Unit at Q₁₀₀₆ (SN76514N) and fed through bandpass filter networks for each band, which remove any spurious responses outside of the desired band. The signal is then amplified by Q₁₀₁₁, Q₁₀₁₂ (2SC1923R), and Q₁₀₁₂ (2SC2407) and fed to the LO port of the diode ring. The premix local signal is generated by Q₃₀₂₅–Q₃₀₃₃ (2SC380TMY), located on the AF Unit.

The 8.9875 MHz IF signal is fed to pin 5 of J₂₀₀₁. The signal is passed through XF₂₀₀₁, a 20 kHz monolithic crystal filter which provides early protection against IMD while allowing enough bandwidth and delay time to match the noise

blanker gate pulses. The signal then passes through noise blanker diodes D₂₀₀₁ and D₂₀₀₃, which act as a switch driven by noise blanker controller Q₂₀₁₄ (MPSA13). The IF signal then is fed through the main SSB or CW filter (CW filter optional); on AM, the signal passes around the SSB/CW filter.

The filtered IF signal is delivered to mixer Q₂₀₀₁ (3SK73GR), where the 8.9875 MHz IF signal is mixed with a 19.7475 MHz $\pm\Delta f$ local signal delivered from oscillator Q₂₀₁₅ (2SC535A) and buffer Q₂₀₁₆ (2SC1815Y). The resulting 10.76 MHz signal is fed through crystal filter XF₂₀₀₂, then fed to mixer Q₂₀₀₂/Q₂₀₀₃ (2SK19GR), where the 10.76 MHz signal is mixed with an identical 19.7475 MHz $\pm\Delta f$ signal fed from buffer Q₂₀₁₇ (2SC1815Y), resulting in an 8.9875 MHz signal, the same as the original IF. This process varies the IF across the passband of crystal filter XF₂₀₀₂, resulting in continuously variable width of the IF passband with no change in the beat note of the incoming signal.

The IF signal is then amplified by Q₂₀₀₄ and Q₂₀₀₅ (3SK73GR), the main IF amplifiers, and delivered to pin 2 of J₂₀₀₂ for delivery to the AF Unit.

A portion of the output from Q₂₀₀₅ is fed to buffer Q₂₀₁₈ (2SC1815Y) and detected by D₂₀₂₄ and D₂₀₂₅ (1N60), resulting in a DC voltage. This voltage is amplified by Q₂₀₁₉ (2SC1815Y) and fed to gate 2 of the RF and IF amplifiers, providing automatic gain control of those stages. The AGC voltage is also amplified by Q₂₀₂₀ (2SK19GR) and Q₂₀₃₁ (2SA733A) for delivery to the front panel LED display for indication of the received signal strength.

When the noise blanker is switched on, a portion of the output from Q₂₀₀₉ is amplified by Q₂₀₁₀, Q₂₀₁₁ (2SC1583G) and Q₂₀₁₂ (2SC1815Y). When a carrier or noise-free modulated signal is received, the IF signal is rectified by D₂₀₁₇ and D₂₀₁₈ (1N60), producing a DC voltage. This DC voltage is amplified by Q₂₀₁₃ (2SC1815Y), which charges C₂₀₆₃ for AGC purposes. The AGC voltage is used to control the gain of Q₂₀₁₀ and Q₂₀₁₁.

When impulse-type noise is received, D₂₀₁₉ and D₂₀₂₀ (1N60) rectify the IF signal, which controls the noise blanker switch, Q₂₀₁₄.

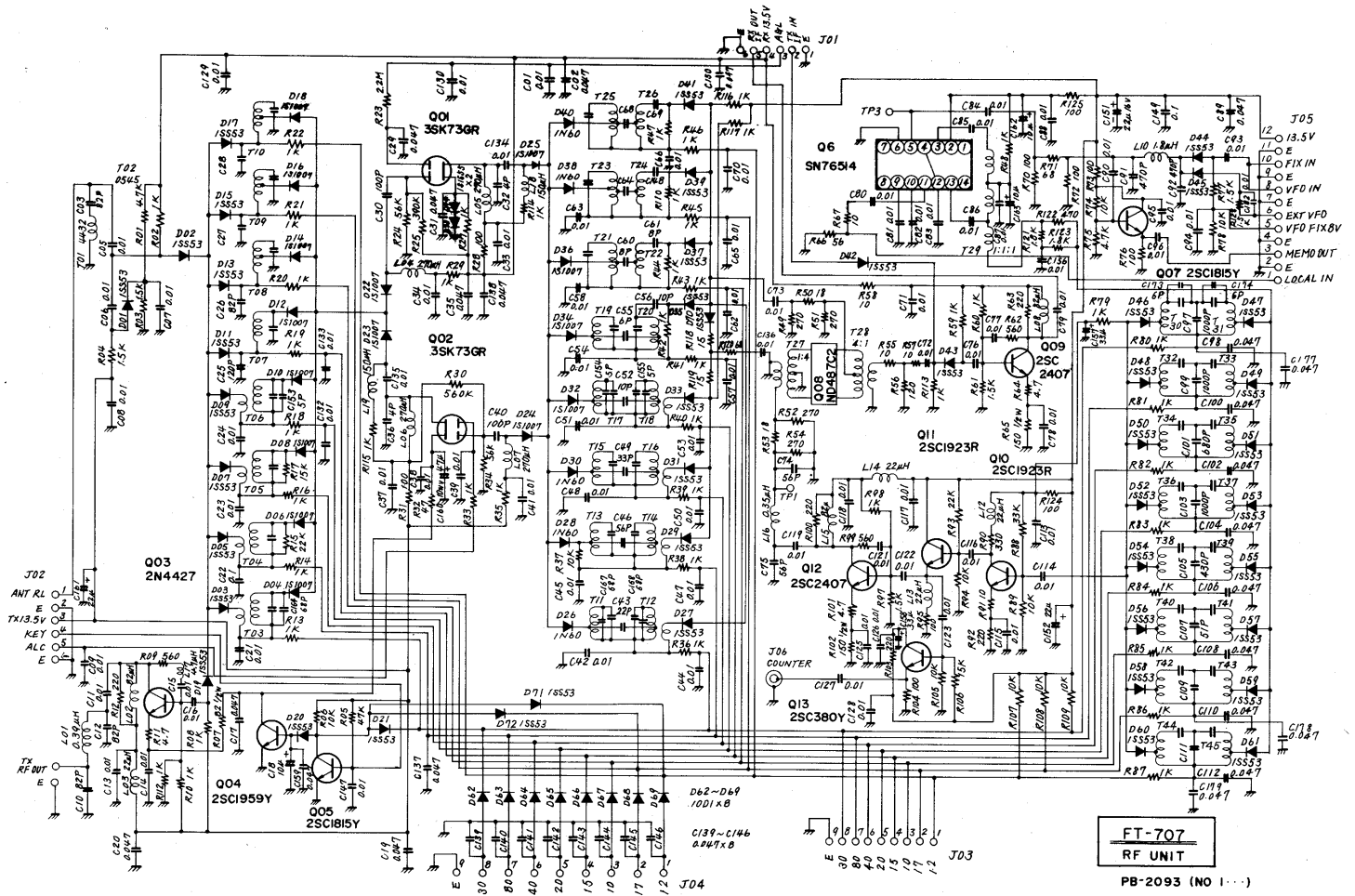

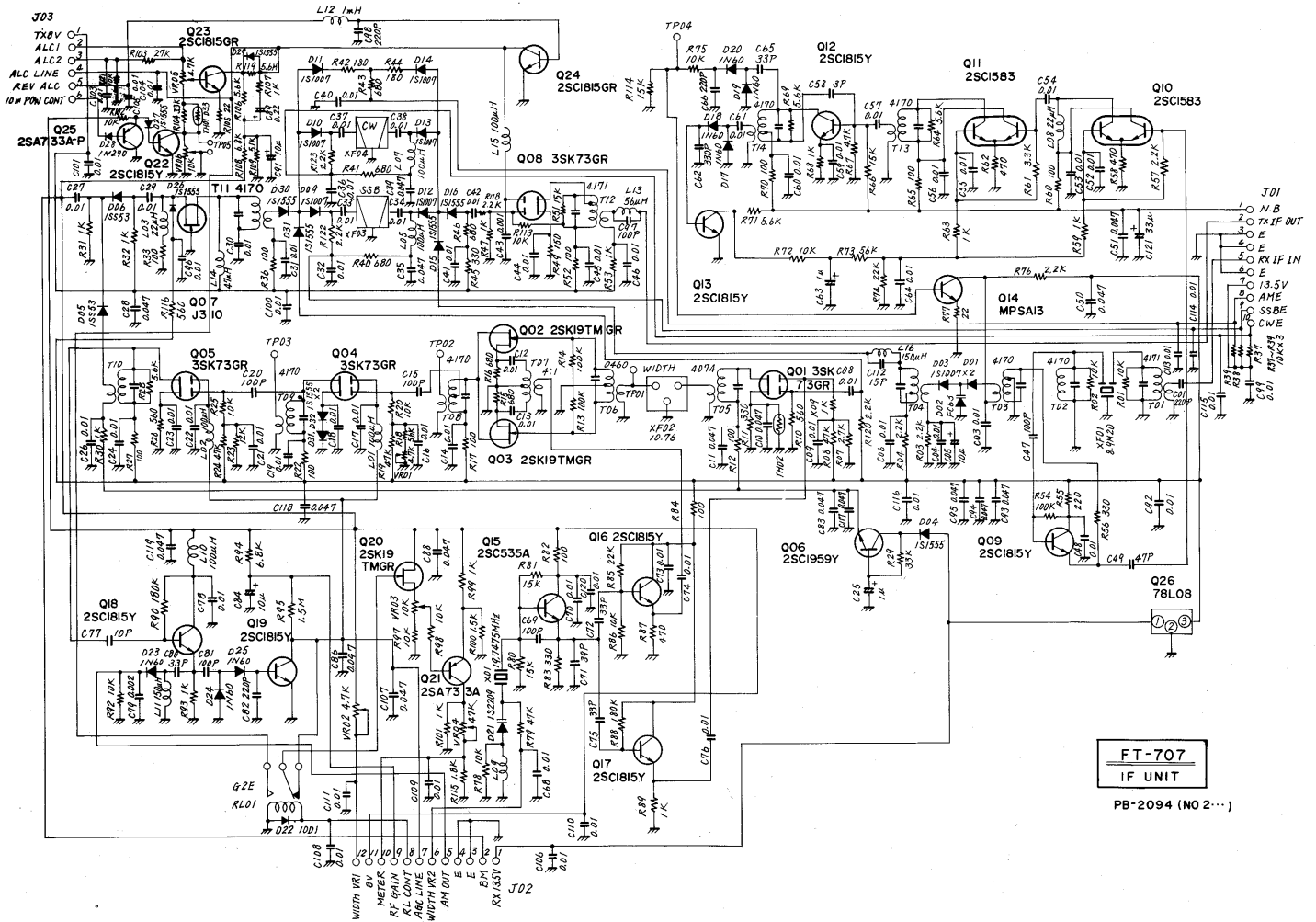

Noise pulses have a very short duration, but high amplitude. Because of the very short time constant of the C_{2063}/R_{2072} discharge path, AGC voltage is not induced by these short-duration pulses. Therefore, Q_{2010} and Q_{2011} operate at full gain, providing maximum voltage to the base of Q_{2014} . When a pulse is received, therefore, Q_{2014} biases D_{2001} and D_{2003} to block the signal path momentarily. When a desired signal and a noise pulse are received simultaneously, the blanking action is not impaired, because the relative difference between the desired signal and the noise pulse is still high.

In the AM mode, a portion of the output from Q_{2018} is detected by D_{2023} (1N60) and delivered to the AF Unit. Filtering in the AM mode is accomplished by XF_{2002} .

AF UNIT (PB-2095)

The SSB or CW signal at pin 1 of J_{3001} is fed through T_{3001} to the diode ring demodulator, $D_{3007}-D_{3010}$ (1S1007), where the IF signal is converted to audio using the carrier signal supplied by crystal oscillator Q_{3004} (2SK19GR) and buffer

Q_{3005} (2SC1815Y). The carrier oscillator provides signals at the following frequencies:

LSB	8986 kHz
USB/CW(RX)	8989 kHz
CW(TX)/AM(TX)	8988.3 kHz

The audio signal is amplified by Q_{3020} and Q_{3021} (2SC1815Y) and fed to final AF amplifier Q_{3022} (μ PC2002V), which provides three watts of audio output to the speaker through an output transformerless circuit.

The audio spectrum is shaped by an active low-pass filter at Q_{3020} of $f_c = 2.7$ kHz, -12 dB/octave.

MARKER GENERATOR

A 25 kHz marker generator is available, for alignment and testing purposes. Marker generator Q_{3036} (2SC380TMY) provides a basic 3200 kHz signal, which is divided into 25 kHz multiples by Q_{3037} (F4024), a binary counter. The output signal is fed through buffer Q_{3038} (2SC380TMY) to the receiver front end.

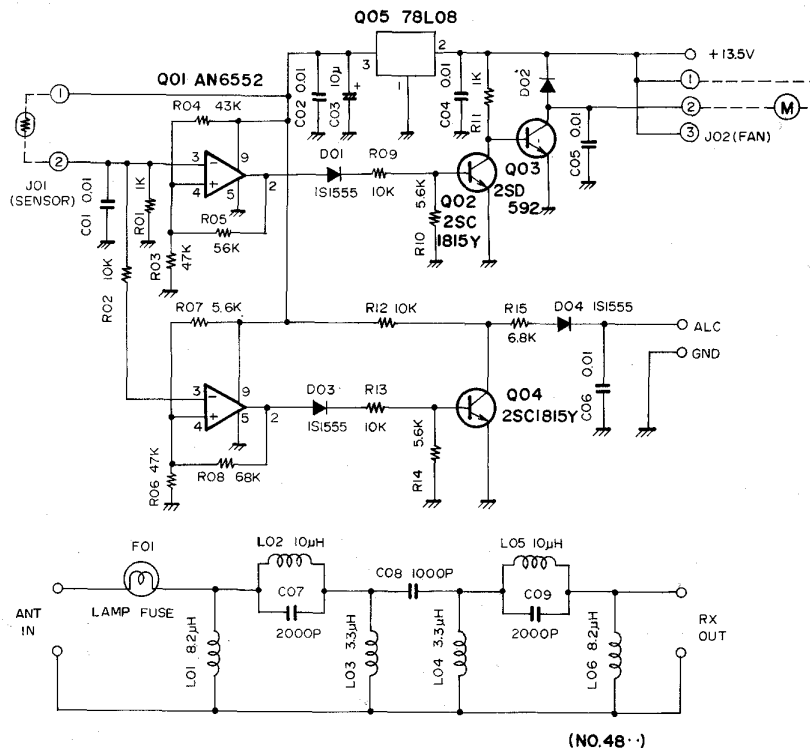

PB-2101

FT-707
HPF UNIT

TRANSMITTER

The discussion of the signal flow on transmit will be on a mode-by-mode basis.

SSB

The audio input signal from the microphone jack, J₃, is fed to pin 9 of J₃₀₀₇ on the AF Unit. The speech signal is amplified by Q₃₀₀₆ (2SC732GR) and Q₃₀₀₇ (2SC1815Y) and then fed through the front panel MIC GAIN control, VR_{3b}. The signal is then applied through buffer Q₃₀₀₈ (2SC1959Y) to the ring modulator, D₃₀₀₇-D₃₀₁₀. Here the audio signal modulates the carrier signal delivered from Q₃₀₀₅, resulting in an 8.9875 MHz double-sideband signal. The signal is then fed to pin 1 of J₃₀₀₁ for delivery to the IF Unit.

The IF signal appearing at pin 2 of J₂₀₀₂ is fed through buffer Q₂₀₀₇ (J310) to the SSB filter, where the unwanted sideband is sliced out. The resulting SSB signal is amplified by Q₂₀₀₈ (3SK73GR) and delivered to the diode ring mixer, Q₁₀₀₈, where the IF signal is mixed with the local signal from the premix circuit. The RF signal is then amplified by Q₁₀₀₂ (3SK73GR) and Q₁₀₀₃ (2N4427), and delivered to the PA Unit.

The input signal is amplified by pre-driver Q₄₂₀₁ (2SC1589) and the push-pull driver stage, Q₄₂₀₂/Q₄₂₀₃ (2SC2395), and amplified further by the push-pull final amplifier, Q₄₂₀₂/Q₄₂₀₅ (2SC2290), which provides approximately 100 watts of RF output. The RF signal is fed through bandswitch low-pass filter networks on the LPF Unit, then delivered, through a directional coupler, to the rear panel antenna jack.

CW

For CW, the 8988.3 kHz carrier signal is generated by Q₃₀₀₄ and fed through buffer Q₃₀₀₅ to the ring modulator, which is unbalanced for CW operation by the application of DC 8V through D₃₀₀₁ (1S1555) and RL₃₀₀₁. The signal path is then identical to that of the SSB signal, up to the latter stage of the RF Unit.

The key line is connected to the base of Q₁₀₀₅ (2SC1815Y). With the key open, Q₁₀₀₅ is biased ON, turning bias controller Q₁₀₀₄ (2SC1959Y) OFF. In this case, the emitters of Q₁₀₀₂ and Q₁₀₀₃ are open, and no output signal will result. When the key is closed, Q₁₀₀₄ will be turned ON, and Q₁₀₀₂ and Q₁₀₀₃ will be keyed, allowing normal transmission. The key lead is also connected to

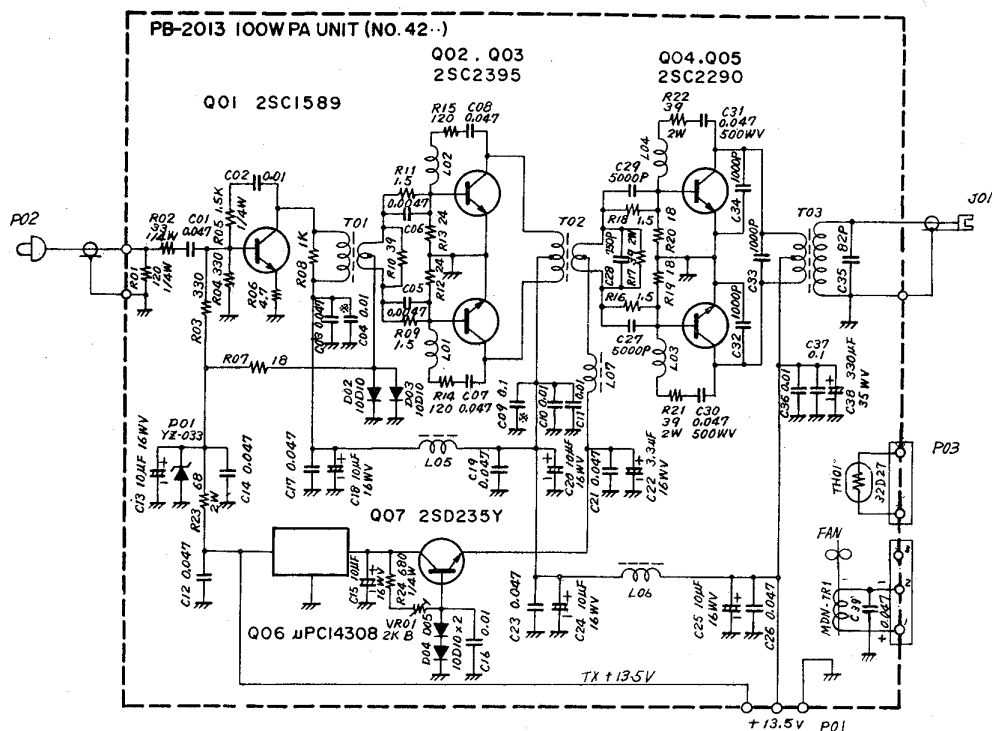

sidetone oscillator Q₃₀₁₀ (2SC1815Y), for monitoring of the code signal during CW operation. The output from Q₃₀₁₀ is delivered to the final AF amplifier, Q₃₀₂₂.

AM

The microphone signal modulates the 8988.3 kHz carrier signal, and the resulting signal is amplified by Q₂₀₀₇ and passed around the SSB filter. From Q₂₀₀₈, the signal path is the same as that on SSB.

ALC CIRCUIT

A variety of level control systems are included in the FT-707, for protection against overdrive, excess temperature, or high SWR.

At the directional coupler, the output voltage is sensed. When a high SWR condition exists, the voltage is detected by D₄₀₀₄ and D₄₀₀₆ (1SS16)

and amplified by Q₂₀₂₄ (2SC1815Y) and fed to the RF, IF, and AF stages of the transmitter, controlling the gain of those stages. In the case of overdrive, the ALC voltage is detected by D₄₀₀₅ and D₄₀₀₇ (1SS16) and amplified by Q₂₀₂₃ (2SC1815Y) for control of the aforementioned stages.

A thermistor on the final amplifier board provides detection of excess temperature. When the operating temperature of the final transistors rises to an unacceptable figure, control voltage developed at comparator Q₄₈₀₁ (AN6552) is fed to Q₄₈₀₂ (2SC1815Y), which drives Q₄₈₀₃ (2SD592), providing operating voltage for a cooling fan on the amplifier heat sink. Control voltage is also fed from Q₄₈₀₁ to amplifier Q₄₈₀₄ (2SC1815Y), and this voltage is delivered to the ALC line to the RF, IF, and AF stages.

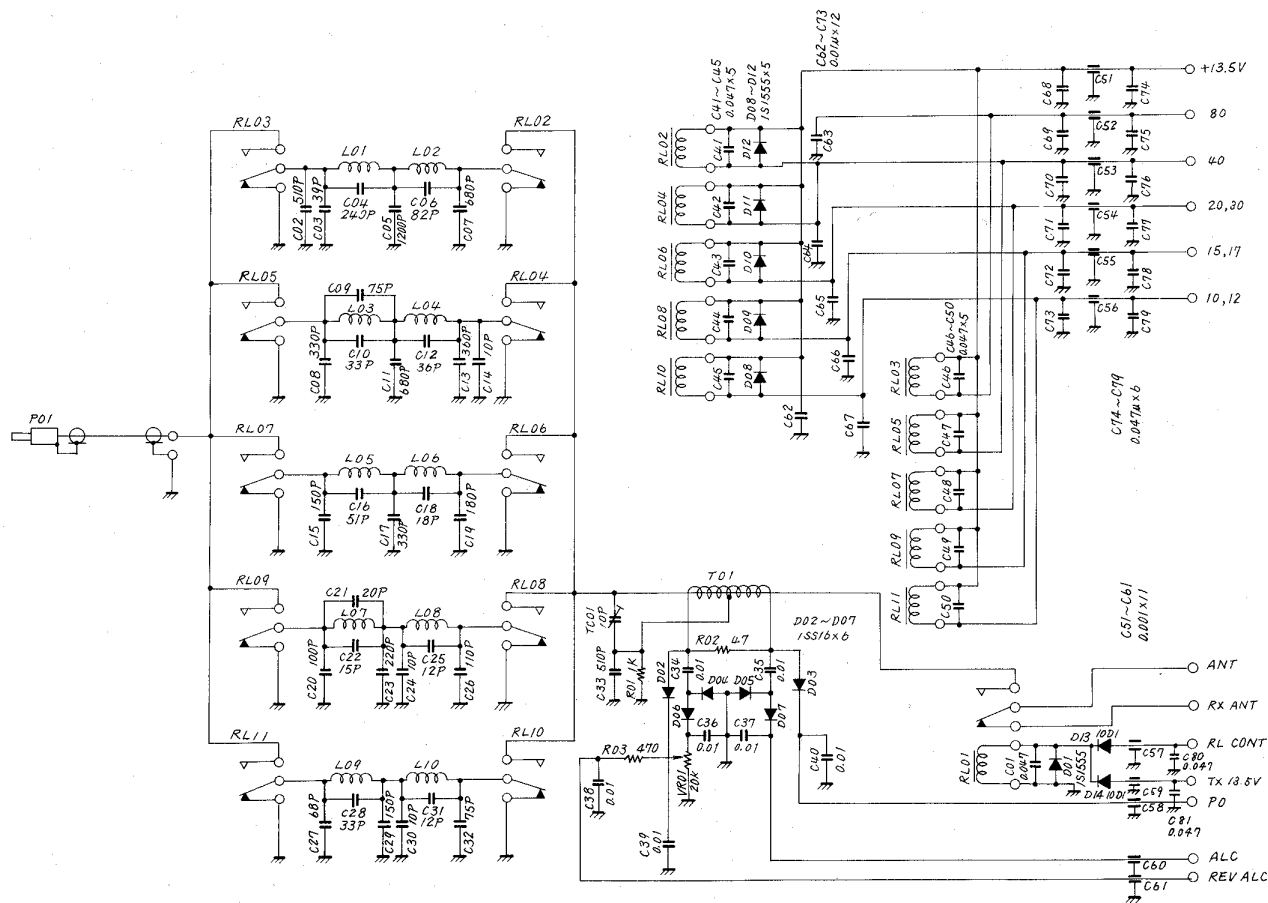

FT-707
LPF UNIT

PB-2128 (NO.40-)

COMMON CIRCUIT

VOX circuit

A portion of the microphone input signal is amplified by Q₃₀₁₁ (2SY1815Y) and detected by D₃₀₁₄ (1N60), producing a DC voltage. This voltage is amplified by Q₃₀₁₂ (2SC1815Y) and Q₃₀₁₃ (2SA733). Q₃₀₁₃ drives Schmitt trigger Q₃₀₁₄/Q₃₀₁₈ (2SC1815Y); when Q₃₀₁₈ is driven ON, relay driver Q₃₀₁₉ (2SA496Y) is turned ON, activating the antenna relay. An RC circuit composed of front panel DELAY control VR₅₁₀₁ and C₃₀₄₃ sets the relay hang time by delaying the cutoff of Q₃₀₁₃ when speech input stops.

A portion of the speaker output is amplified by Q₃₀₁₅ (2SC1815Y) and detected by D₃₀₁₅ (1N60). This provides a bucking voltage which is amplified by Q₃₀₁₆ (2SC1815Y) and Q₃₀₁₇ (2SA733) and fed to Q₃₀₁₃, preventing the speaker output from tripping the VOX circuit.

VFO UNIT (PB-2097)

VFO oscillator Q₄₃₀₁ (2SC1815Y) operates in a modified Colpitts configuration, providing a 5.0–5.5 MHz VFO signal. The 500 kHz tuning range is tuned by variable capacitor VC₄₃₀₁, which is a two-section capacitor. The sub-blades of VC₄₃₀₁ provide temperature compensation against frequency change caused by thermal expansion of the main blades. The VFO signal is fed through buffer amplifiers Q₄₃₀₂ (2SK19GR) and Q₄₃₀₃ (2SC1815Y), passed through a low-pass filter, and fed, through diode switches D₁₀₄₄/D₁₀₄₅ (1S1555), to the premix IC, Q₁₀₀₆.

Varactor diode D₄₃₀₁ is placed in the oscillator circuit during clarifier operation. In accordance with the tuning of the front panel clarifier control and L₄₃₀₆, the capacitance variation induced in D₄₃₀₁ allows offset from the main dial frequency of ± 2.5 kHz.

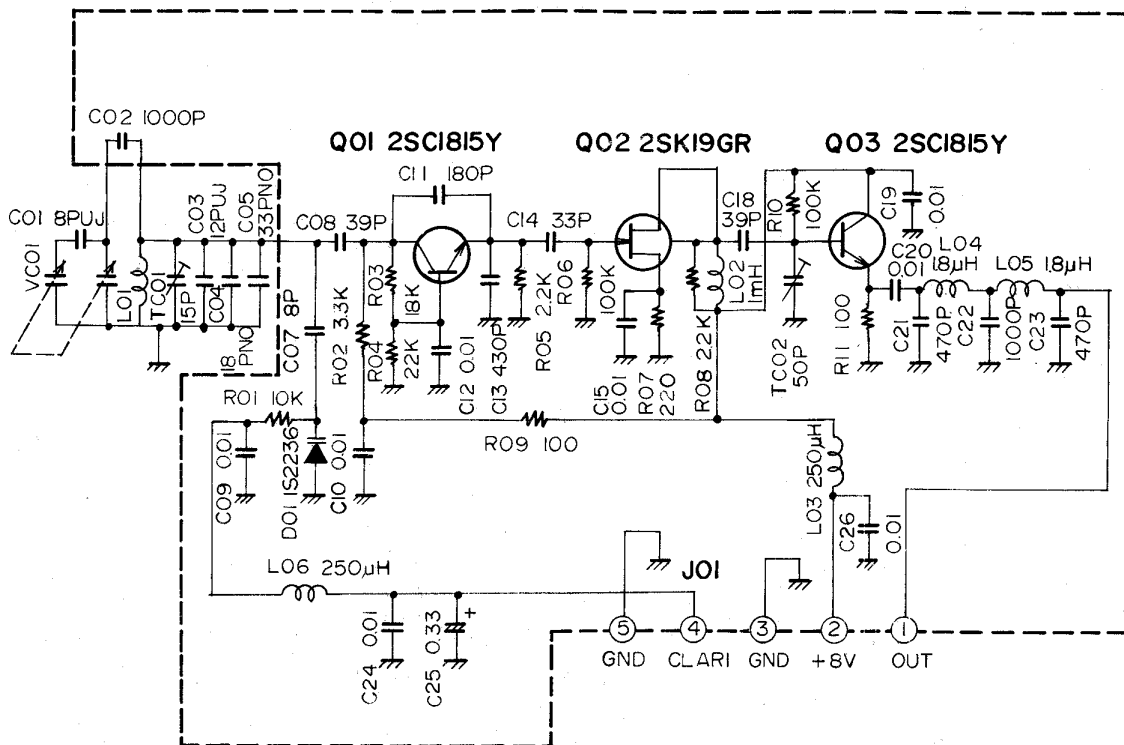

FT-707
VFO UNIT

PB-2097(NO.43..)

PREMIX CIRCUIT (AF UNIT)

The premix local signal is generated by crystal oscillator $Q_{3025}-Q_{3033}$ (2SC380TM-Y), the oscillator in use being selected by diode switches $D_{3029}-D_{3037}$ (1S1555). The output from the oscillator passes through Pin 2 of J_{1006} and Pin 1 of J_{1005} in the RF Unit. This signal is fed to Pin 11 of the IC double balanced mixer (Q_{1006}).

The 5.0–5.5 MHz VFO signal is fed through Pin 8 of J_{1005} , to the diode switch selecting either FIX or VFO, and to a low-pass filter. Next, this signal passes to the mixer, where the VFO signal is mixed up with the premix local signal, resulting in the output premix signal, shown in Table 3.

The premix signal is passed through a broadband transformer and a bandswitched bandpass filter, which eliminates spurious signals on the premix output. Selection of the desired filter is performed by the diode switches of $D_{1046}-D_{1057}$ (1SS53). The filtered signal is then amplified by a three-stage amplifier chain consisting of Q_{1010} , Q_{1011} (2SC1923R), and Q_{1012} (2SC2407). Finally, the signal is delivered to the double balanced mixer, which provides the TX and RX IF signal.

A portion of the output from Q_{1011} is amplified by buffer Q_{1013} (2SC380TM-Y) for delivery to the frequency counter for display purposes.

		XCO Frequency MHz	PREMIX OUT Frequency MHz
80m	X_{3005}	17.9845	12.4875–12.9875
40m	X_{3006}	21.4845	15.9875–16.4875
30m	X_{3004}	24.4875	18.9875–19.4875
20m	X_{3007}	28.4875	22.9875–23.4875
17m	X_{3013}	32.4875	26.9875–27.4875
15m	X_{3008}	35.4875	29.9875–30.4875
12m	X_{3014}	38.9875	33.4875–33.9875
10mA	X_{3009}	42.4875	36.9875–37.4875
10mB	X_{3010}	42.9875	37.4875–37.9875
10mC	X_{3011}	43.4875	37.9875–38.4875
10mD	X_{3012}	43.9875	38.4875–38.9875

Table 3

	Nominal Premix Local Frequency (MHz)	LSB (MHz)	USB (MHz)	CW. AM (MHz)
80m	12.4875–12.9875	12.486–12.986	12.489–12.989	12.4883–12.9883
40m	15.9875–16.4875	15.986–16.486	15.989–16.489	15.9883–16.4883
30m	18.9875–19.4875	18.986–19.486	18.989–19.489	18.9883–19.4883
20m	22.9875–23.4875	22.986–23.486	22.989–23.489	22.9883–23.4883
17m	26.9875–27.4875	26.986–27.486	26.989–27.489	26.9883–27.4883
15m	29.9875–30.4875	29.986–30.486	29.989–30.489	29.9883–30.4883
12m	33.4875–33.9875	33.486–33.986	33.489–33.989	33.4883–33.9883
10mA	36.9875–37.4875	36.986–37.486	36.989–37.489	36.9883–37.4883
10mB	37.4875–37.9875	37.486–37.986	37.489–37.989	37.4883–37.9883
10mC	37.9875–38.4875	37.986–38.486	37.989–38.489	37.9883–38.4883
10mD	38.4875–38.9875	38.486–38.986	38.489–38.989	38.4883–38.9883

Table 4

COUNTER UNIT (PB-2086A)

A portion of the local oscillator signal appears at the F IN terminal of the COUNTER Unit, where it is amplified by Q₄₄₀₁ (3SK73) and Q₄₄₀₃ (2SC1674L). The signal is then fed to the LSI counter chip, Q₄₀₁₂ (MSM9520RS). A portion of the output from Q₄₄₀₃ is detected by D₄₄₀₁ and D₄₄₀₂ (1S1555) and amplified by Q₄₄₀₄

(2SC1815Y), providing an AGC voltage which keeps the signal input level to the LSI constant by controlling the gain of Q₄₄₀₁.

The output from the LSI drives LED digit drivers Q₄₄₀₆–Q₄₄₁₁ (2SA952L) and segment drivers Q₄₄₁₃–Q₄₄₁₉ (2SA952L), which control the digital display light emitting diodes, D₄₅₀₁–D₄₅₀₆ (HP5082–7623).

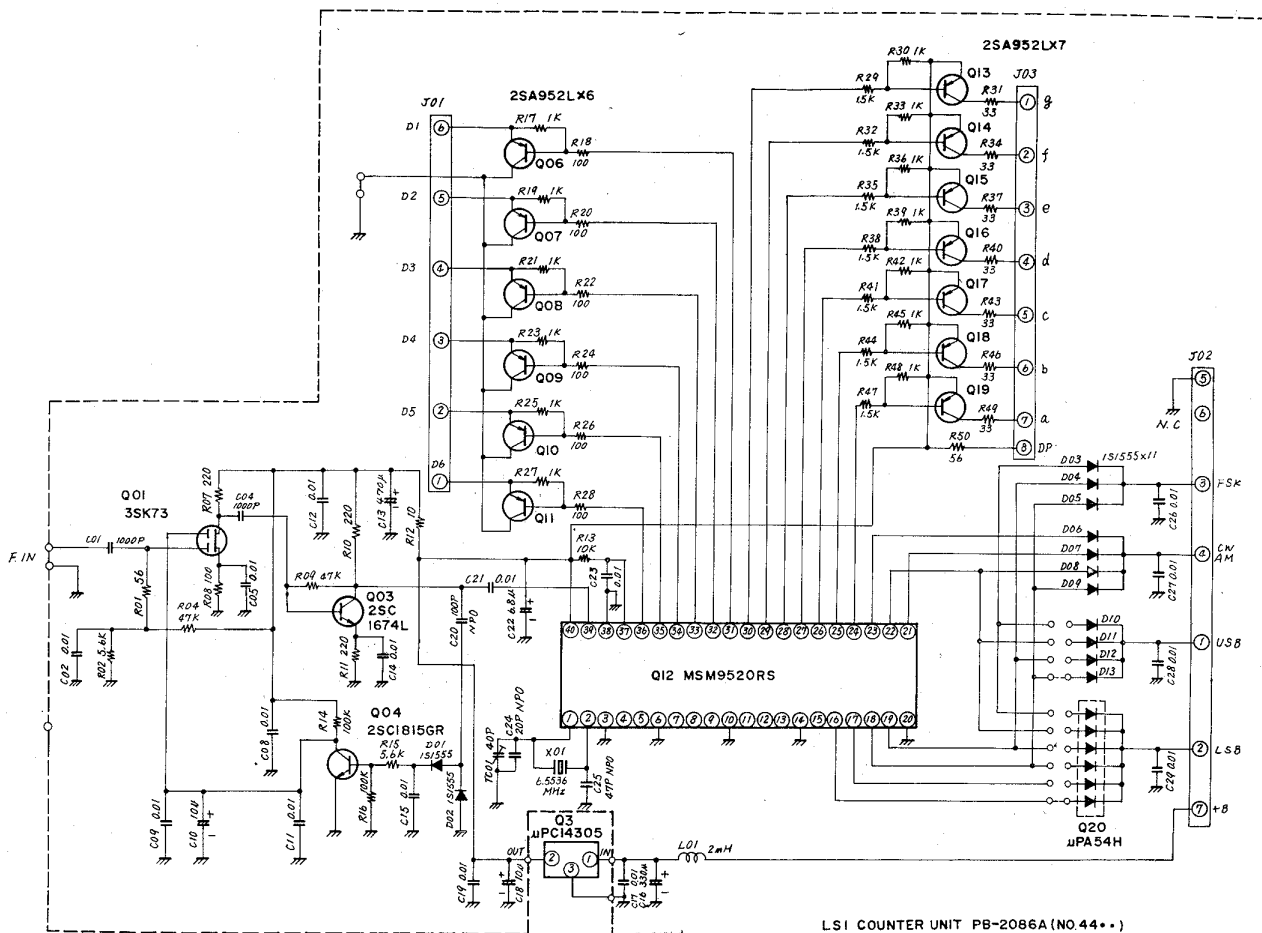
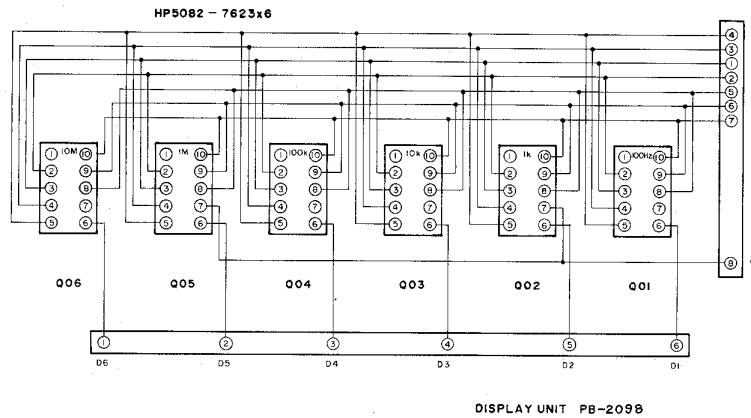

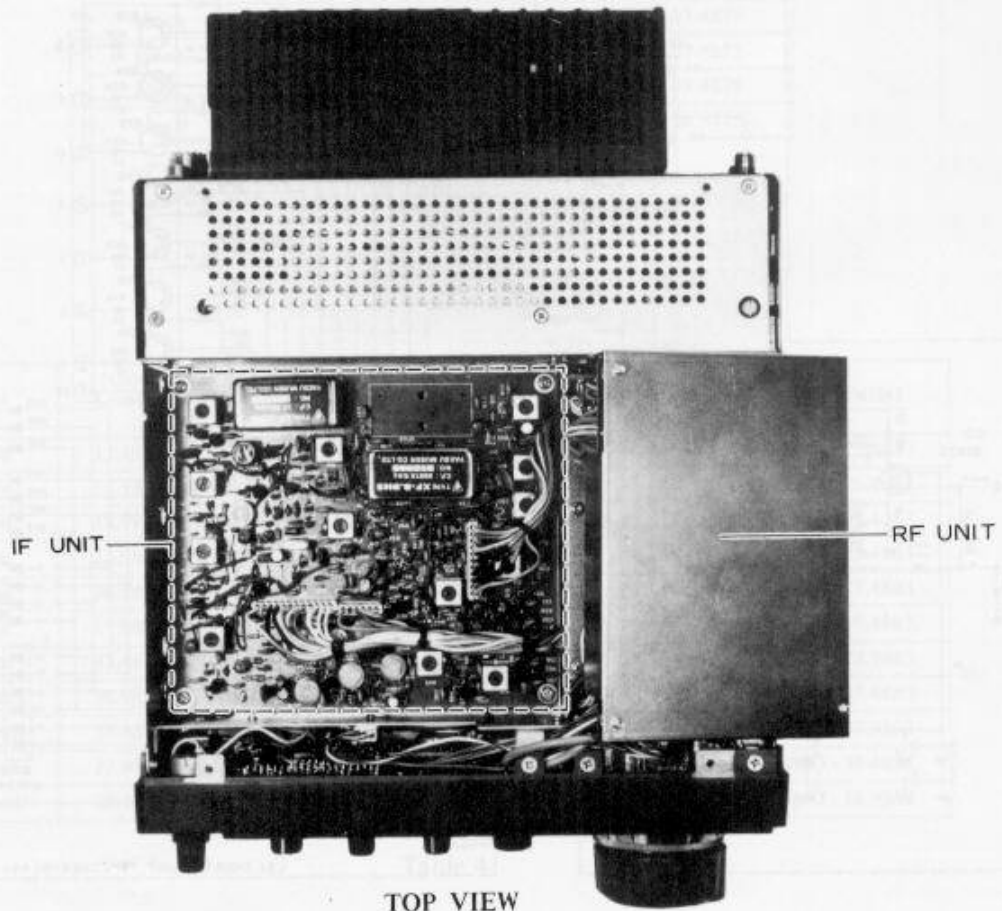
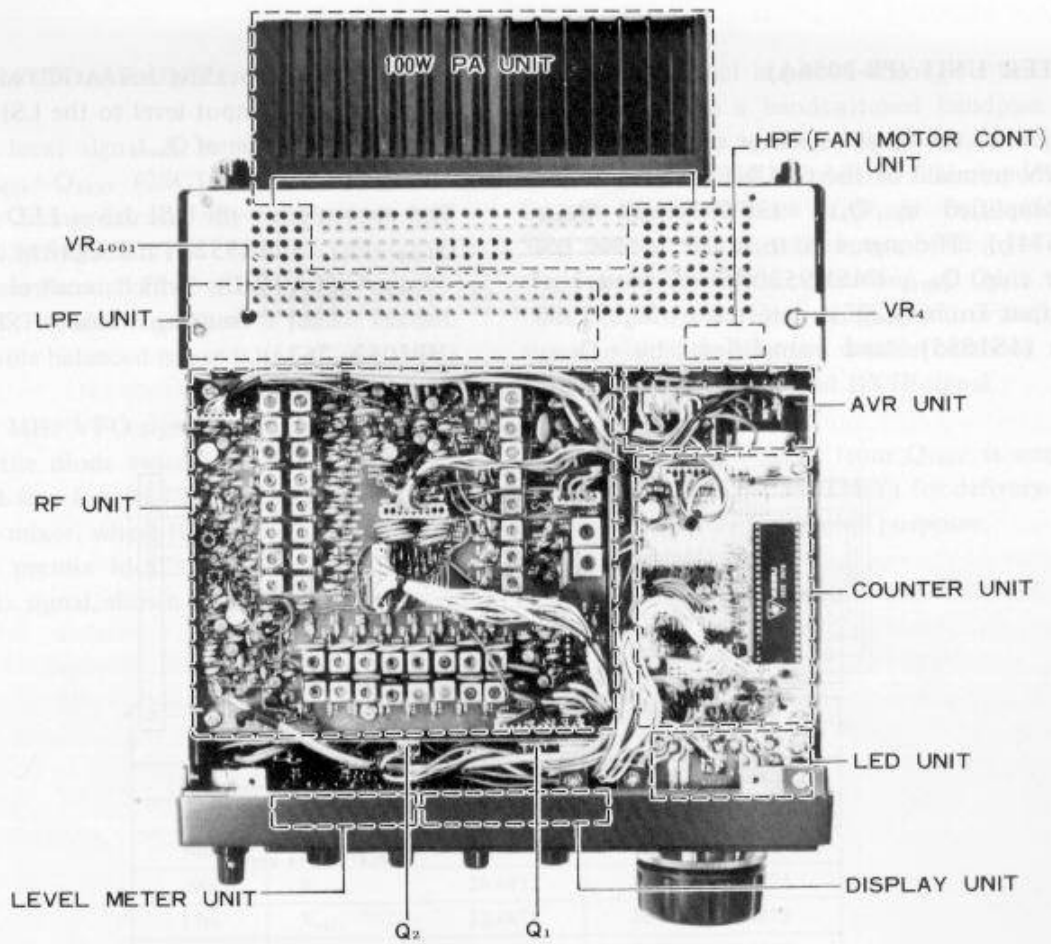

MAINTENANCE AND ALIGNMENT

This transceiver has been carefully aligned and tested at the factory. With normal use, it should not require other than the usual attention given to electronic equipment.

Service or replacement of a major component may require substantial adjustment. Under no circumstances, though, should realignment be attempted unless the operation of the transceiver is fully understood, the malfunction has been carefully analyzed, and the fault has definitely been traced to misalignment. Sudden difficulties are almost always caused by component failure, rather than misalignment.

Service must be performed only by experienced personnel, using the proper test equipment.

EQUIPMENT REQUIRED

- (1) RF Signal Generator: Hewlett-Packard Model 606A or equivalent, with one volt output at 50 ohms, and frequency coverage to 30 MHz.
- (2) Vacuum Tube Voltmeter (VTVM): Hewlett-Packard Model 410B or equivalent, with an RF probe good to 40 MHz.
- (3) Dummy Load: Yaesu Model YP-150 or equivalent, with 50 ohm non-reactive load impedance, rated to 150 watts average power.
- (4) AF Signal Generator: Hewlett-Packard Model 200 AB or equivalent.
- (5) A general coverage receiver covering 3 to 30 MHz, with a 100 kHz crystal calibrator.
- (6) Frequency Counter: Yaesu Model YC-500 or equivalent, with resolution to 0.01 kHz and frequency coverage to 30 MHz.
- (7) Oscilloscope: Hewlett-Packard Model 1740A or equivalent.

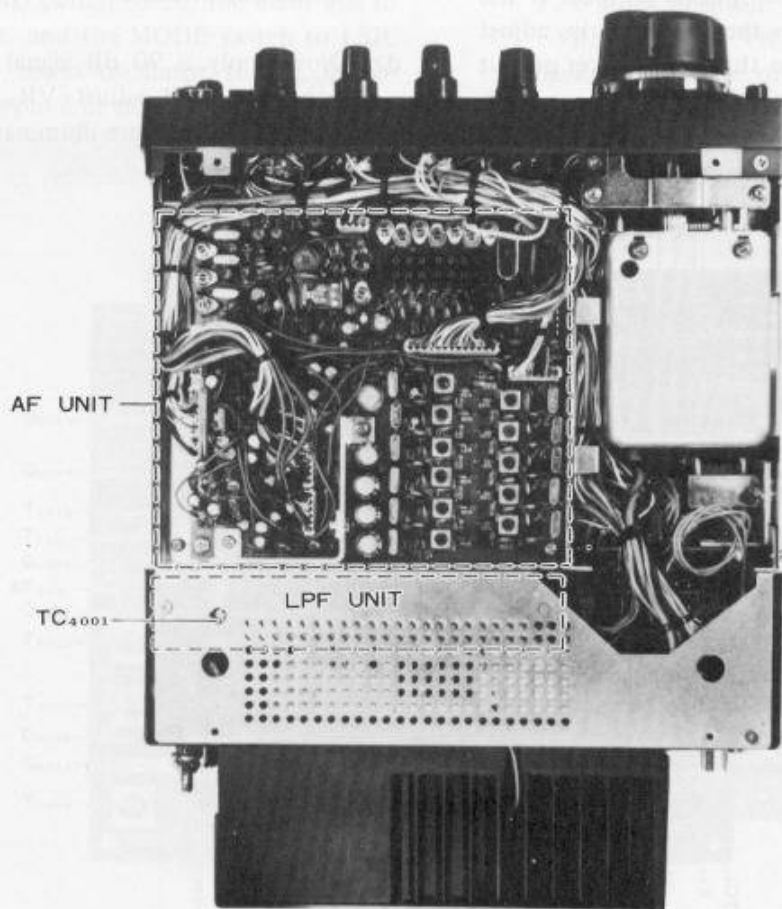

BOTTOM VIEW

NOTE REGARDING MEASUREMENT LEVELS

Where decibel levels are quoted in the following section (e.g. "Apply a 90 dB signal..."), the reference used is 0 dB = 1 μV. At 50 ohms, this level is equivalent to -107 dBm.

- d) Now recheck the previous test using your voice to activate the VOX. Do not advance the VOX control nor VR₃₀₀₃ farther than necessary for proper performance, as confusing results will be obtained if these controls are advanced too far.

VOX ADJUSTMENT
(VOX GAIN/ANTITRIP SETTING)

- a) Set up the transceiver for reception on any band. Set the AF GAIN control for a comfortable listening level. The MODE switch should be set to LSB or USB.
- b) Without closing the PTT switch, hold the microphone near your mouth, and speak in a normal voice into the microphone. Advance the VOX control until your voice activates the transmitter.
- c) Without closing the PTT switch, hold the microphone near the speaker output. If the speaker audio causes the VOX to trip, adjust VR₃₀₀₃ (AF Unit) so that the speaker output does not activate the transmitter.

S-METER ALIGNMENT

- a) Set the BAND switch to 20, the main tuning dial to 14.250 MHz, and the RF GAIN control fully clockwise.
- b) Connect a signal generator to the antenna jack, and tune its output to the receiver frequency.
- c) With no signal applied from the signal generator, adjust VR₂₀₀₃ (IF Unit) so that none of the LEDs on the level meter are illuminated. Do not go beyond the threshold point required for complete darkening of the entire line of LEDs.
- d) Now apply a 90 dB signal from the signal generator, and adjust VR₂₀₀₄ (IF Unit) so that all 10 LEDs are illuminated.

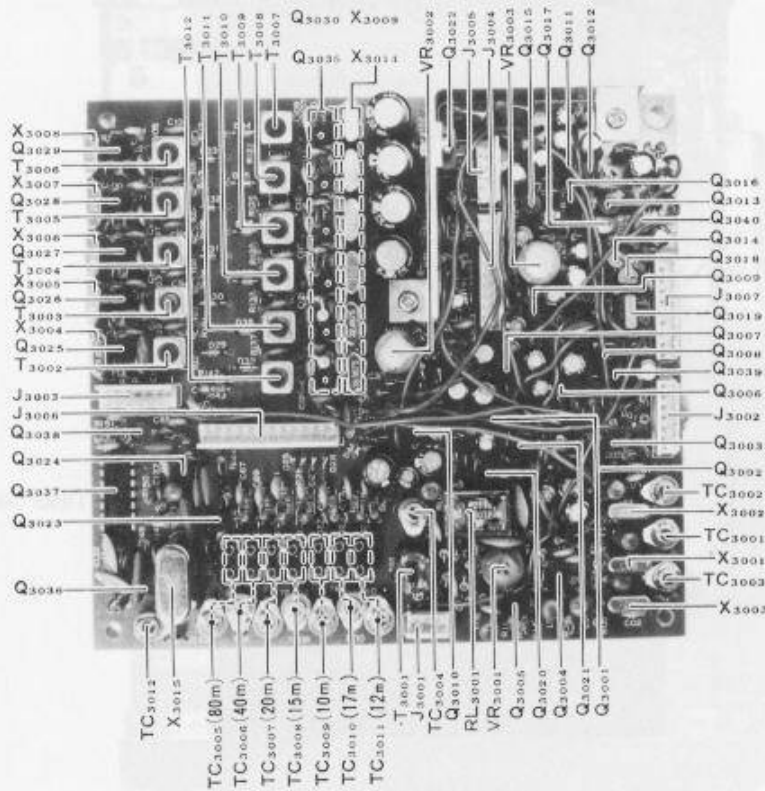

AF UNIT

TOP VIEW

CW SIDETONE LEVEL ADJUSTMENT

- Adjust VR₃₀₀₂, located on the AF Unit, for the desired CW sidetone level.

MARKER ALIGNMENT

- Set the BAND switch to 30, and the MODE switch to AM. Adjust the AF GAIN control for a comfortable listening volume on the standard frequency station.
- Push the MARK switch, and listen for evidence of a beat between the marker signal and the standard frequency station. If there is any beat note, adjust TC₃₀₁₂ (AF Unit) for a zero beat between the calibrator and the standard frequency station.

CARRIER POINT ALIGNMENT

- Set the BAND switch to 20, the main dial to 14.250 MHz, and the MODE switch to LSB. Connect an audio oscillator to the microphone input, pin 8 of the mic jack.

- Set the audio oscillator frequency to 1500 Hz, and its output level to 5 mV. Close the MOX switch, and advance the MIC control to achieve an output power of 60 watts as indicated on the dummy load/wattmeter.
- Without changing any level settings, set the audio oscillator output frequency to 300 Hz, and adjust TC₃₀₀₁ (AF Unit) for a power output of 15 watts, as indicated on the dummy load/wattmeter.
- Set the MODE switch to USB, and repeat the above procedure on USB.
- Switch back and forth between USB and LSB. If there is any difference in the pitch of the background receiver noise, adjust the WIDTH control presetting as described below.

IF WIDTH ALIGNMENT

- Set the front panel WIDTH control to the 12 o'clock position. Switch between LSB and USB, and adjust VR₂₀₀₂ (IF Unit) so that the background noise of the receiver is identical on both modes.

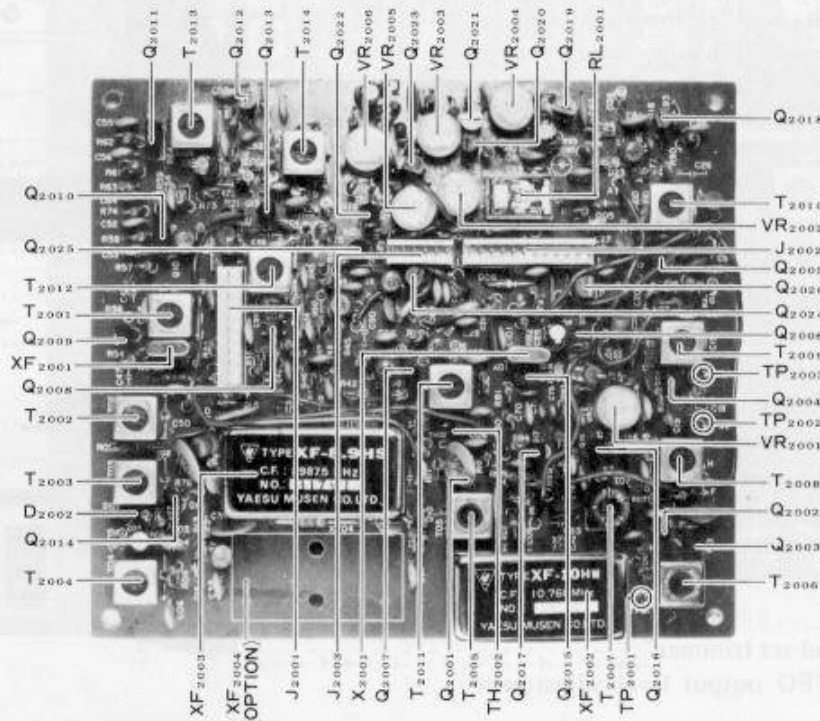

IF UNIT

CARRIER BALANCE ADJUSTMENT

- a) Set the BAND switch to 20, the main dial to 14.250 MHz, and the MODE switch to LSB. Set the MIC control fully counterclockwise, and remove all oscillator or other modulation sources from the mic input.
- b) With an external receiver tuned to the FT-707 transmitting frequency, adjust VR₃₀₀₁ and TC₃₀₀₄ (AF Unit) for minimum signal indication on the external receiver with the MOX switch of the FT-707 closed.
- c) Now set the MODE switch to USB, and check the results. Adjust VR₃₀₀₁ and TC₃₀₀₄ again, if needed, to assure optimum carrier nulling. Then check the LSB results again. Several passes may be necessary.

CW CARRIER POINT ALIGNMENT

- a) Set the BAND switch to 20, the main dial to 14.250 MHz, and the MODE switch to CW.
- b) Lightly couple the probe of a precision frequency counter to the coax cable between the antenna jack and the dummy load. Close the PTT switch, and close the key. Adjust TC₃₀₀₃ (AF Unit) so that the frequency on the counter is exactly the same as that on the digital display.

VFO UNIT

The VFO is very critical in its adjustment. As well, this is not an area which should require servicing. For this reason, we recommend that all cases of VFO repair be referred to a Yaesu service center. Cases of VFO instability or drift can almost always be traced to a fault elsewhere in the system, such as instability in a supply voltage, etc.

From a service standpoint, however, two components are of interest:

TC₄₃₀₁ is the band set trimmer.

TC₄₃₀₂ is the VFO output level adjustment trimmer.

To confirm proper VFO injection, connect the RF probe of the VTVM to TP₁₀₀₃ (RF Unit). Adjust TC₄₃₀₂ for a reading of 50 mV on the VTVM.

LOCAL OSCILLATOR CIRCUITS

(1) Premix Bandpass Filter Adjustment

- a) Connect a jumper between TP₁₀₀₂ and TP₁₀₀₃ (RF Unit). Connect a sweep generator at that point. Connect the oscilloscope (through a detector) to TP₁₀₀₁ (RF Unit).
- b) Refer to Table 5, and apply sweep on each band shown at the proper frequency. Adjust the cores of the transformers shown in Table 5 for the pattern shown in Figure 5.
- c) Now connect the RF probe of the VTVM to TP₁₀₀₁. Refer to Table 6, and adjust the cores shown for each band for a reading of 700 mV on each band.

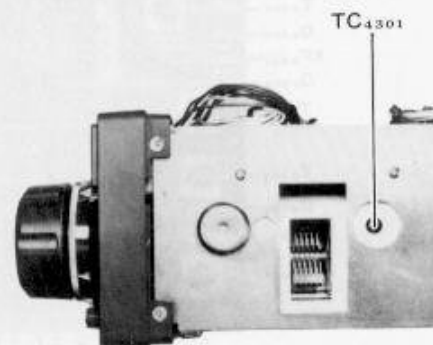
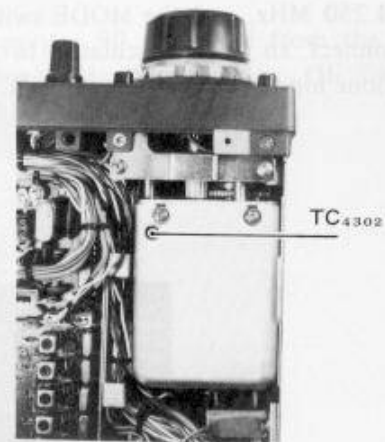

VFO

BAND	TRANSFORMER	PASS BAND MHz
80m	T ₁₀₃₂ T ₁₀₃₁	12.5-13.0
40m	T ₁₀₃₄ T ₁₀₃₅	16.0-16.5
30m	T ₁₀₃₀ T ₁₀₃₁	19.0-19.5
20m	T ₁₀₃₆ T ₁₀₃₇	23.0-23.5
17m	T ₁₀₄₂ T ₁₀₄₃	27.0-27.5
15m	T ₁₀₃₈ T ₁₀₃₉	30.0-30.5
12m	T ₁₀₄₄ T ₁₀₄₅	33.5-34
10m	T ₁₀₄₀ T ₁₀₄₁	37-39

Table 5

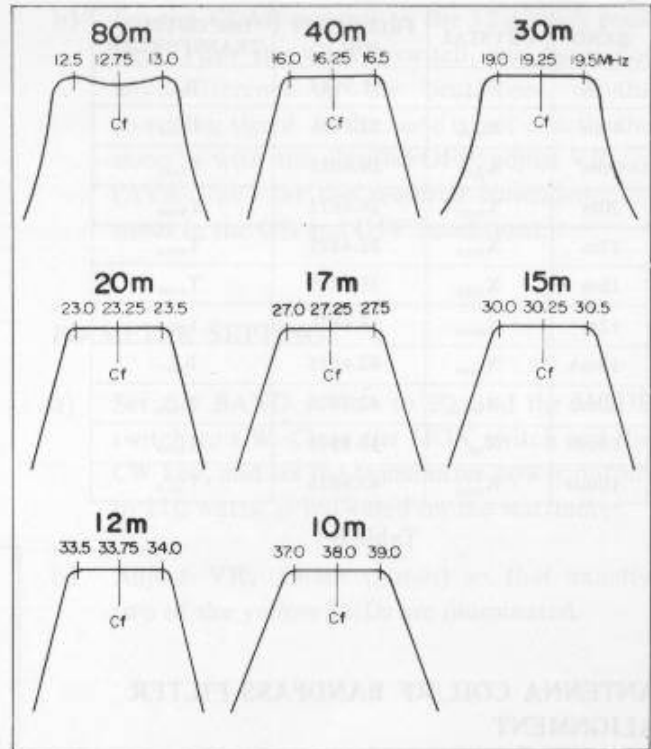
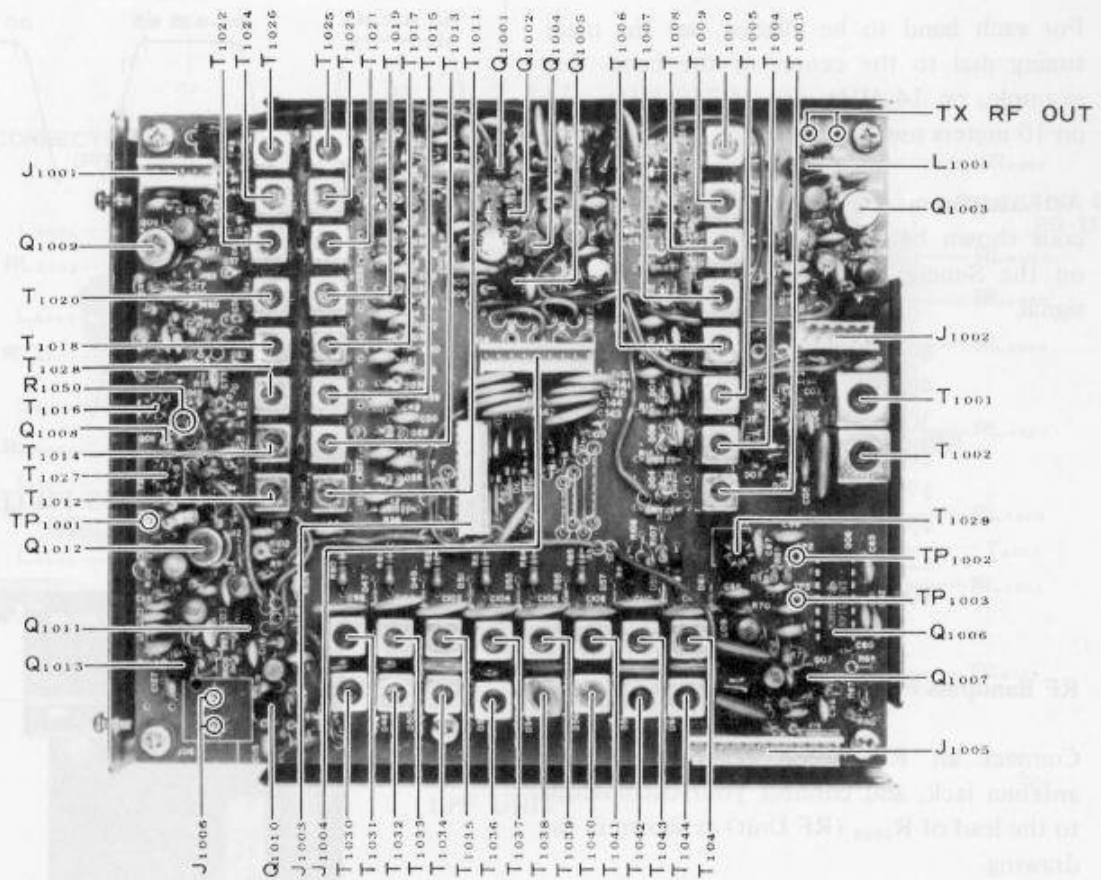

Figure 5 PREMIX BANDPASS FILTER



RF UNIT

BAND	CRYSTAL	FREQUENCY MHz	OSC OUTPUT TRANSFORMER
80m	X ₃₀₀₅	17.9845	T ₃₀₀₃
40m	X ₃₀₀₆	21.4845	T ₃₀₀₄
30m	X ₃₀₀₄	24.4875	T ₃₀₀₁
20m	X ₃₀₀₇	28.4875	T ₃₀₀₅
17m	X ₃₀₁₃	32.4875	T ₃₀₁₁
15m	X ₃₀₀₈	35.4875	T ₃₀₀₆
12m	X ₃₀₁₄	38.4875	T ₃₀₁₂
10mA	X ₃₀₀₉	42.4875	T ₃₀₀₇
10mB	X ₃₀₁₀	42.9875	T ₃₀₀₈
10mC	X ₃₀₁₁	43.4875	T ₃₀₀₉
10mD	X ₃₀₁₁	43.9875	T ₃₀₁₀

Table 6

ANTENNA COIL/RF BANDPASS FILTER ALIGNMENT

(1) Antenna Coil Adjustment

- a) For each band to be aligned, set the main tuning dial to the center of the band. For example, on 14 MHz, use 14.250 MHz, and on 10 meters use 29.0 MHz.
- b) Activate the marker generator, and adjust the coils shown below for maximum deflection on the S-meter when tuned to the marker signal.

80	T ₁₀₀₄
40	T ₁₀₀₅
30	T ₁₀₀₃
20	T ₁₀₀₆
17	T ₁₀₀₉
15	T ₁₀₀₇
12	T ₁₀₁₀
10	T ₁₀₀₈

(2) RF Bandpass Filter Adjustment

- a) Connect an RF sweep generator to the antenna jack, and connect your oscilloscope to the lead of R₁₀₅₀ (RF Unit) as shown in the drawing.
- b) Adjust the transformers shown in Table 7 for the pattern shown in Figure 6.

BAND	TRANSFORMER	PASS BAND MHz
80m	T ₁₀₁₃ + T ₁₀₁₄	3.5-4.0
40m	T ₁₀₁₅ + T ₁₀₁₆	7.0-7.0
30m	T ₁₀₁₁ + T ₁₀₁₁	10.0-10.5
20m	T ₁₀₁₇ + T ₁₀₁₈	14.0-14.5
17m	T ₁₀₂₃ + T ₁₀₂₄	18.0-18.5
15m	T ₁₀₁₉ + T ₁₀₂₀	21.0-21.5
12m	T ₁₀₂₁ + T ₁₀₂₆	24.5-25.0
10m	T ₁₀₂₁ + T ₁₀₂₂	28.0-29.7

Table 7

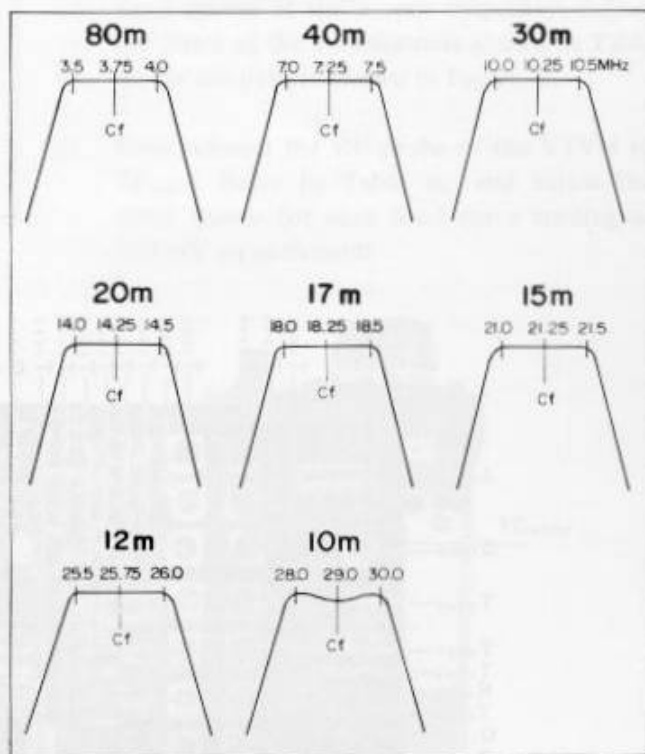
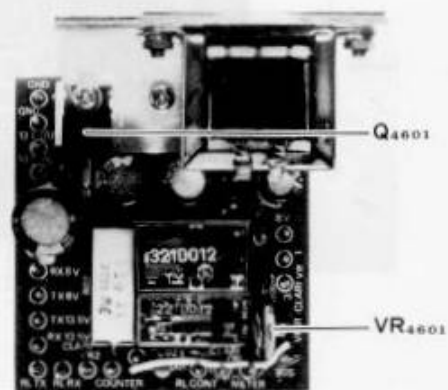

Figure 6 RF BANDPASS FILTER



AVR UNIT

ANTENNA TRAP COIL ALIGNMENT

- a) Set the BAND switch to 40, and set the main tuning dial to 7.5 MHz. Connect an audio voltmeter to the speaker jack.
- b) Connect a signal generator to the antenna jack, and apply a 100 dB signal at 8.9875 MHz. Adjust T₁₀₀₁ (RF Unit) for minimum indication on the audio voltmeter.

CLARIFIER ALIGNMENT

- a) On any band, apply a signal from the signal generator, and tune the receiver to the output from the signal generator. If desired, you may use the marker signal instead of a signal generator. With the clarifier OFF, note the beat tone of the incoming signal, with the MODE switch set to CW.

- b) Set the CLAR control to the 12 o'clock position. Push the CLAR switch, and listen for any difference in the beat tone of the incoming signal. If the tone is not exactly the same as with the clarifier OFF, adjust VR₄₀₀₁ (AVR Unit) for the required coincidence of tones in the ON and OFF conditions.

PO METER SETTING

- a) Set the BAND switch to 20, and the MODE switch to CW. Close the MOX switch and the CW key, and set the transmitter power output to 110 watts, as indicated on the wattmeter.
- b) Adjust VR₄ (main chassis) so that exactly two of the yellow LEDs are illuminated.

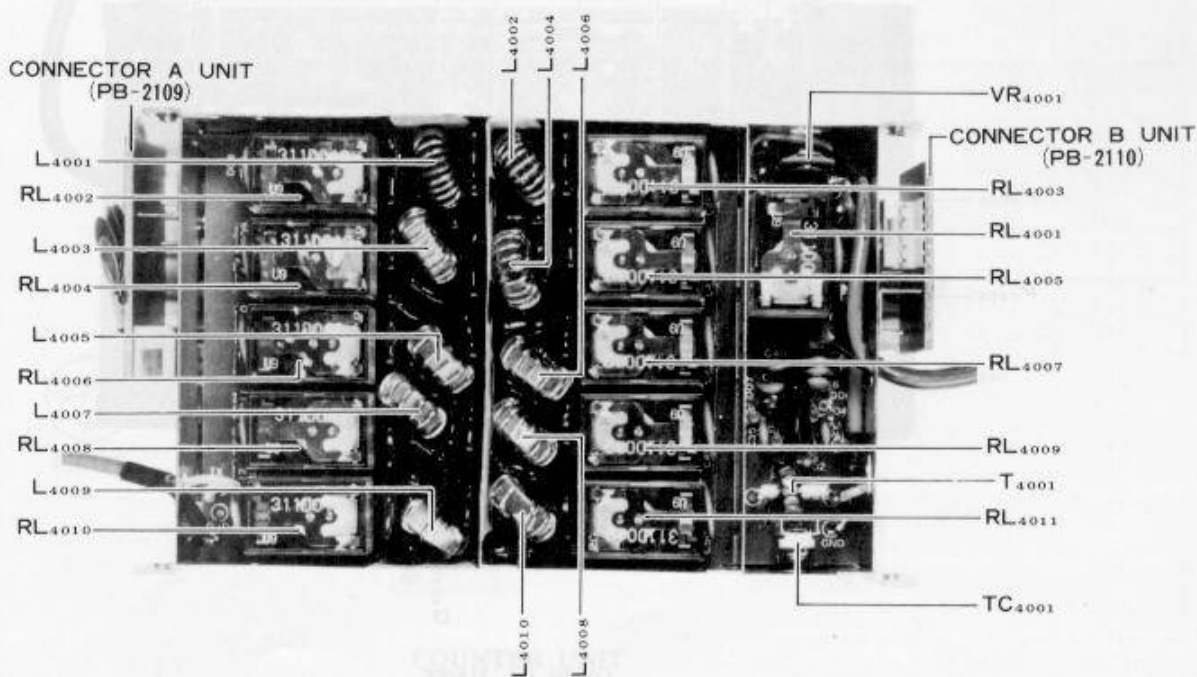

LPF UNIT

DIRECTIONAL COUPLER BALANCE

- Set the BAND switch to 15, and the MODE switch to CW. Connect the MINUS (-) lead of your DC voltmeter to the center post of VR₄₀₀₁ (connect the positive lead of the voltmeter to ground).
- Transmit on CW, and adjust TC₄₀₀₁ for a minimum indication on the voltmeter.

ALC CIRCUIT ALIGNMENT

- Set the MODE switch to CW. On each band, check the maximum power output. Set VR₂₀₀₅ for a maximum power output of 110 watts. Use a 50 ohm dummy load for this step.
- Connect a 17 ohm load to the antenna jack (three 50 ohm dummy loads connected in parallel). Transmit on 20 meter CW, and adjust VR₄₀₀₁ for a maximum power output of 50 watts as indicated on the wattmeter.

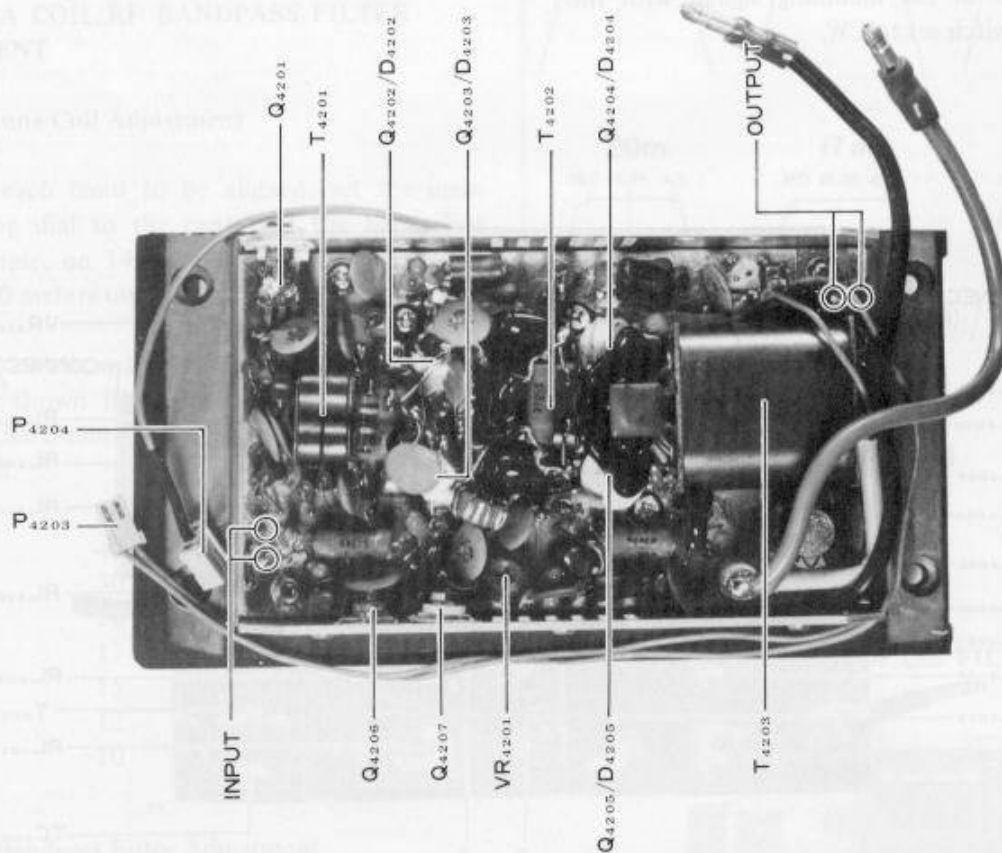

100W PA UNIT

COUNTER UNIT

- Set the BAND switch to 10D, the main dial to 30.0 MHz, and the MODE switch to LSB or USB.
- Switch on the calibrator, and tune for a zero beat on the marker signal. Now adjust TC₄₄₀₁ (COUNTER Unit) for a reading of exactly 30.000.0 MHz on the transceiver digital display.

OTHER TRANSMIT/RECEIVE TRANSFORMERS

- Tune to the marker signal at 14.250 MHz. Adjust IN ORDER T₂₀₀₁ through T₂₀₁₀ for maximum deflection on the level meter (S-meter). T₂₀₀₁–T₂₀₁₀ are located on the IF Unit.
- Close the PTT switch, and transmit in the CW mode. Adjust T₂₀₁₁ and T₂₀₁₂ (IF Unit) for maximum power output.
- Connect the signal generator to the antenna jack, and set its output to 10 dB at 14.250 MHz. Tune the receiver to the signal generator output, with the MODE switch set to USB. Connect a DC voltmeter (+ terminal) to TP₂₀₀₄, and adjust T₂₀₁₃ and T₂₀₁₄ (IF Unit) for maximum deflection on the DC voltmeter.

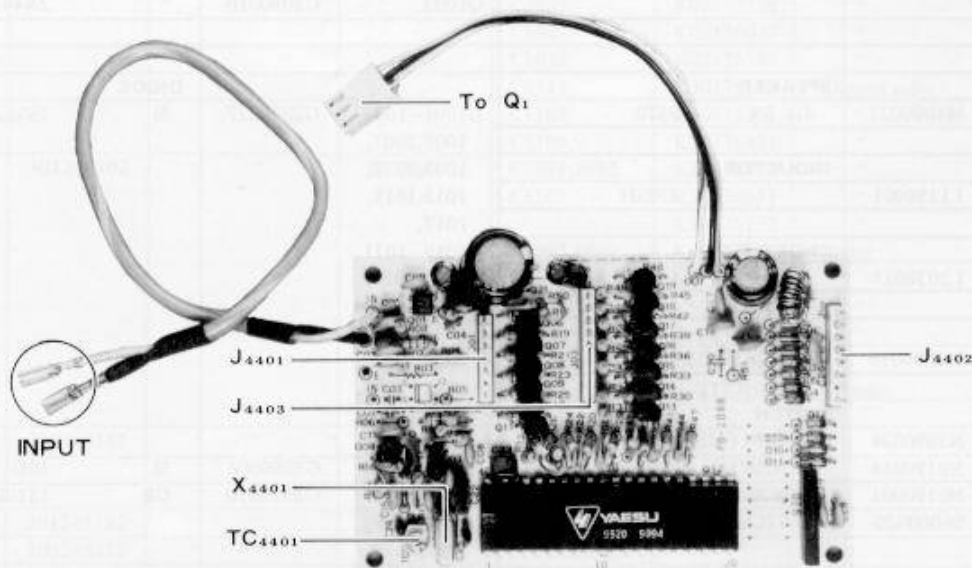

COUNTER UNIT

PARTS LIST

MAIN CHASSIS			PLUG		
Symbol No.	Parts No.	Description	P1	P1090074	5047-07A
			P10	P1090153	PI051-04F
		IC	P16,18	P1090154	PI051-05F
Q1	G1090065	μ PC14305	P2,3,9,14,19	P1090155	PI051-06F
Q2	G1090070	μ PC14308	P11,12	P1090156	PI051-07F
			P4,5	P1090158	PI051-09F
		DIODE	P17	P1090159	PI051-10F
D1,2	G2090001	Si 10D1	P7,13	P1090160	PI051-11F
D3	G2090142	LED TLR-226	P6,8	P1090161	PI051-12F
			P15	P1090162	PI091-13F
		RESISTOR	P21	P1090186	3021-03A
R4	J01245560	Carbon film 1/4W TJ 56 Ω			
R8	J01245680	" " " " 68 Ω		S6000060	Speaker terminal
R7	J01245151	" " " " 150 Ω			
R3	J01245152	" " " " 1.5k Ω			
R6	J10276479	" composition 1/2W GK 4.7 Ω			
R1	J10276100	" " " " 10 Ω			
R2	J10276101	" " " " 100 Ω			
			RF UNIT		
			Symbol No.	Parts No.	Description
		POTENTIOMETER		C0020930	PCB with Components
VR1	J62800043	DM10A668A-5KB-5KA		F0002093	Printed Circuit Board
VR2	J62800044	DM10E572A-5KBX2			
VR3	J62800045	DM10A667A-5KA-5KB			IC, FET & TRANSISTOR
VR4	J60800069	DM10A624C-20KB	Q1006	G1090062	IC SN76514N
			Q1008	G2090135	Diode Quad ND487C2-3R
		CAPACITOR	Q1001,1002	G4800730	FET 3SK73GR
C2	K13170103	Ceramic 50WV 0.01 μ F	Q1013	G3303800Y	TR 2SC380TM-Y
C3,4	K13170473	" " " " 0.047 μ F	Q1005,1007	G3318150Y	" 2SC1815Y
CI	K40120338	Electrolytic 25WV 3300 μ F	Q1010,1011	G3319230R	" 2SC1923R
			Q1004	G3319590Y	" 2SC1959Y
			Q1009,1012	G3324070	" 2SC2407
			Q1003	G3090010	" 2N4427
		SPEAKER			DIODE
SP1	M4090027	4 Ω 3W SS70	D1001-1003, 1005,1007, 1009,1011, 1013,1015, 1017, 1019-1021, 1027,1029, 1031,1033, 1035,1037, 1039,1041, 1042-1061, 1070,1071, 1072	G2090027	Si 1S553
		INDUCTOR			
L1	L1190001	250 μ H			
		CHOKE COIL			
CH1	L2030017	1.7mH			
		RELAY			
RL1	M1090010	FRL-263D012/02CK-0E			
		SWITCH			
S1	N2090024	8H2011 (without Switch Lever)			
S2	N0190014	SRN2045N	D1062-1069	G2090001	Si 10D1
S3	N0190001	SRN202CN	D1004,1006, 1008,1010, 1012,1014, 1016,1018, 1022-1025, 1032,1034, 1036,1038, 1040	G2010070	GB 1S1007
	S6000020	SWITCH LEVER, GRAY (for S1)			
		RECEPTACLE			
J1	P1090134	SG7627			
J2	P1090004	SG7814			
J3	P0090158	FM214-8SS			
J4	P1090005	SG8050	D1026,1028, 1030	G2090029	Ge 1N60
J5	P1090028	MBR06B			
J6	P1090152	D8-703B-11			
J7	P1090034	D7-701B-00			
J8	P0090026	QS-IB4M			RESISTOR
J9,10,11	P1090133	STR-01H	R1011,1064	J00245479	Carbon film 1/4W VJ 4.7 Ω

R1101,1126	J00245479	Carbon film	1/4W VJ	4.7Ω	R1024,1034	J00245563	Carbon film	1/4W VJ	56kΩ
R1055,1057, 1058,1067, 1091	J00245100	" "	" "	10Ω	R1025	J00245394	" "	" "	390kΩ
					R1030	J00245564	" "	" "	560kΩ
					R1023	J00245225	" "	" "	2.2MΩ
R1118,1119	J00245150	" "	" "	15Ω					
R1050,1053	J00245180	" "	" "	18Ω					
R1032	J00245470	" "	" "	47Ω					
R1066	J00245560	" "	" "	56Ω					
R1071,1120	J00245680	" "	" "	68Ω					
R1007	J00245820	" "	" "	82Ω					
R1026,1028, 1031,1070, 1072,1073, 1076,1095, 1104,1124, 1125	J00245101	" "	" "	100Ω	C1032,1036, 1171,1172, 1175,1176	K02172040	Ceramic	50WV NPO	4pF
					C1068, 1153-1155	K02172050	" "	" "	5pF
					C1055,1173, 1174	K02173060	" "	" "	6pF
					C1166	K02173070	" "	" "	7pF
R1056	J00245121	" "	" "	120Ω	C1060,1061	K02173080	" "	" "	8pF
R1065,1102	J10276151	Carbon composition			C1064	K02173090	" "	" "	9pF
			1/2W "	150Ω	C1056,1069	K02173100	" "	" "	10pF
R1012,1063, 1092,1100, 1103	J00245221	Carbon film	1/4W VJ	220Ω	C1052				
					C1148	K02175120	" "	" "	12pF
					C1169,1170	K02175150	" "	" "	15pF
R1049,1051, 1052,1054	J00245271	" "	" "	270Ω	C1043,1165	K02179009	" "	" "	22pF
					C1049	K02175330	" "	" "	33pF
R1090	J00245331	" "	" "	330Ω	C1043	K02175390	" "	" "	39pF
R1122	J01245471	" "	" TJ	470Ω	C1107	K02179016	" "	" "	51pF
R1009,1062, 1099	J00245561	" "	" VJ	560Ω	C1046,1074, 1075	K02175560	" "	" "	56pF
R1048	J00245681	" "	" "	680Ω	C1164,1167, 1168	K02175680	" "	" "	68pF
R1002,1008, 1010,1027, 1029,1033, 1035,1042, 1044,1047, 1059,1060, 1079,1086, 1087,1098, 1110, 1112-1117	J00245102	" "	" "	1kΩ	C1003,1010, 1012,1026	K02175820	" "	" "	82pF
					C1030,1040	K00175101	" "	" "	SL 100pF
					C1025	K02175121	" "	" "	NPO 120pF
					C1027	K02179027	" "	" "	270pF
					C1028	K02175151	" "	" "	150pF
					C1111	K30176151	Dipped mica	" "	150pF
					C1109	K30176331	" "	" "	330pF
					C1105	K30176431	" "	" "	430pF
R1013,1014, 1016, 1018-1020, 1021,1022, 1036, 1038-1041, 1043,1045, 1046, 1080-1087, 1127	J01245102	" "	" TJ	1kΩ	C1091,1092	K30176471	" "	" "	470pF
					C1101	K30176681	" "	" "	680pF
						K30276102	" "	" "	1000pF
					C1097,1099, 1103	K50177102	Mylar	" "	1000pF
					C1001	K50177103	" "	" "	0.01μF
					C1002,1019, 1035,1089	K50177473	" "	" "	0.047μF
R1003,1004, 1061,1077, 1097,1128	J00245152	" "	" VJ	1.5kΩ	C1005-1009, 1011, 1014-1016, 1021-1024, 1027,1033, 1034,1037, 1038,1039, 1041,1042, 1044,1045, 1047,1048, 1050,1051, 1053,1054, 1057,1058, 1062,1063, 1065,1066, 1070-1073, 1076-1088, 1090	K13170103	Ceramic	" "	0.01μF
R1121,1123	J01245182	" "	" TJ	1.8kΩ					
	J00245222	" "	" VJ	2.2kΩ					
R1001,1075	J00245472	" "	" "	4.7kΩ					
R1006,1037, 1074,1078, 1089,1094, 1105,1107, 1108	J00245103	" "	" "	10kΩ					
R1109	J01245103	" "	" TJ	10kΩ					
R1017,1106	J00245153	" "	" VJ	15kΩ					
R1015,1093	J00245223	" "	" "	22kΩ					
R1088	J00245333	" "	" "	33kΩ					
R1005	J00245473	" "	" "	47kΩ					

XF2004 (OPTION)	H1102019	8.9875MHz	XF8.9HCN	R2013,2014, 2054	J01245104	Carbon film 1/4W TJ 100kΩ
RESISTOR				R2088,2090	J00245184	" " " VJ 180kΩ
R2077,2105	J00245220	Carbon film	1/4W VJ 22Ω		J00245474	" " " " 470kΩ
R2012,2017, 2022,2027, 2033,2036, 2052,2060, 2065,2070, 2082,2084	J00245101	" "	" " 100Ω	R2095	J00245155	" " " " 1.5MΩ
				R2119	J00245565	" " " " 5.6MΩ
						POTENTIOMETER
R2049	J00245151	" "	" " 150Ω	VR2001,2002, 2005	J51723472	SR19R 4.7kΩ
R2042,2044	J00245181	" "	" " 180Ω			
R2055	J01245221	" "	" TJ 220Ω	VR2003,2006	J51723103	" 10kΩ
R2011,2045, 2083	J00245331	" "	" VJ 330Ω	VR2004	J51723473	" 47kΩ
R2056	J01245331	" "	" TJ 330Ω			
R2058,2062, 2087	J00245471	" "	" " 470Ω			THERMISTOR
2010,2026, 2116	J00245561	" "	" " 560Ω	TH2001,2003	G9090003	D33A
				TH2002	G9090009	32D27
R2015,2016, 2043,2046	J00245681	" "	" " 680Ω			
						CAPACITOR
R2040,2041	J01245681	" "	" TJ 680Ω	C2058	K00172030	Ceramic 50WV SL 3pF
R2009, 2030-2032, 2047,2053, 2059,2063, 2068,2089, 2093,2099, 2101,2107	J00245102	" "	" VJ 1kΩ	C2077	K00173100	" " " 10pF
				C2112	K00175150	" " " 15pF
				C2065,2080	K00175330	" " " 33pF
				C2072,2075	K06175330	" " UJ 33pF
				C2071	K06175390	" " " 39pF
				C2049	K00175470	" " SL 47pF
				C2015,2020, 2047,2081, 2097	K00175101	" " " 100pF
R2100	J00245152	" "	" " 1.5kΩ	C2069	K06175101	" " UJ 100pF
R2115	J00245182	" "	" " 1.8kΩ	C2001,2066, 2082,2098	K00175221	" " SL 220pF
R2003,2004, 2057,2076, 2118,2122, 2123	J00245222	" "	" " 2.2kΩ	C2062	K00175331	" " " 330pF
R2120	J01245222	" "	" TJ 2.2kΩ	C2043	K10176102	" " " 0.001μF
R2007	J00245272	" "	" VJ 2.7kΩ	C2017,2018, 2022,2023	K19149013	" 25WV 0.01μF
R2061,2104	J00245332	" "	" " 3.3kΩ			
R2067	J00245472	" "	" " 4.7kΩ	C2004,2006, 2008,2009, 2012,2013, 2014,2016, 2019,2021, 2024,2026, 2027, 2029-2034, 2036-2038, 2040-2042, 2044,2045, 2046,2048, 2052-2057, 2059-2061, 2064,2068, 2070,2073, 2074,2076, 2078,2092, 2096, 2099-2101, 2103, 2104-2106, 2108-2111, 2113,2116, 2170	K13170103	" 50WV 0.01μF
R2109	J00245512	" "	" " 5.1kΩ			
R2018,2028, 2064,2069, 2071,2106	J00245562	" "	" " 5.6kΩ			
R2094,2108	J00245682	" "	" " 6.8kΩ			
R2001,2002, 2020,2025, 2037-2039, 2072,2075, 2078,2086, 2092,2097, 2098,2102, 2113	J00245103	" "	" " 10kΩ			
R2121	J01245103	" "	" TJ 10kΩ			
R2023	J00245123	" "	" VJ 12kΩ			
R2051,2066, 2080,2081, 2114	J00245153	" "	" " 15kΩ			
R2074,2085	J00245223	" "	" " 22kΩ			
R2103	J01245223	" "	" TJ 22kΩ			
R2029	J00245333	" "	" VJ 33kΩ			
R2008,2024, 2079	J00245473	" "	" " 47kΩ			
R2019	J01245473	" "	" TJ 47kΩ			
R2073	J00245563	" "	" VJ 56kΩ	C2079	K13170222	" " 0.022μF

R3081,3149, 3159,3176	J00245221	Carbon film 1/4W VJ 220Ω	R3038,3041, 3042,3092, 3095,3145, 3150	J00245223	Carbon film 1/4W VJ 22kΩ
R3165-3168, 3170	J00245331	" " " " 330Ω	R3018,3024, 3045,3052	J00245333	" " " " 33kΩ
R3100,3104, 3108,3112, 3116,3120, 3124,3128, 3132,3136, 3140,3160, 3161-3164, 3169	J00245391	" " " " 390Ω	R3015,3026, 3030,3058	J00245473	" " " " 47kΩ
			R3073	J00245563	" " " " 56kΩ
			R3006,3025	J00245104	" " " " 100kΩ
			R3070	J00245184	" " " " 180kΩ
			R3177	J00245474	" " " " 470kΩ
R3013,3032, 3040,3062	J00245471	" " " " 470Ω			POTENTIOMETER
R3005,3023, 3048,3050, 3055,3071, 3077,3091, 3094,3148, 3151,3153, 3169	J00245102	" " " " 1kΩ	VR3001	J51727101	CR19R 100Ω
			VR3002,3003	J51723103	SR19R 10kΩ
					CAPACITOR
			C3137	K00172030	Ceramic 50WV SL 3pF
			C3068,3070, 3072,3074, 3076,3078, 3080	K02175150	" "NPO 15pF
R3142	J01245122	" " " TJ 1.2kΩ	C3014	K02179008	" " " 20pF
R3049,3051, 3147	J00245222	" " " VJ 2.2kΩ	C3138	K00175220	" " SL 22pF
R3173	J00245272	" " " " 2.7kΩ	C3133	K02179011	" "NPO 27pF
R3004,3014, 3022,3047, 3054,3075, 3084-3090, 3098,3102, 3106,3110, 3114,3118, 3122,3126, 3130,3134, 3138,3154	J00245332	" " " " 3.3kΩ	C3004-3006, 3109,3113, 3117,3121	K02175390	" " " 39pF
			C3105	K02175560	" " " 56pF
			C3010,3011, 3093,3101	K02175101	" " " 100pF
			C3129	K02175470	" " " 47pF
			C3125	K02175820	" " " 82pF
			C3089	K02175121	" "NPO 120pF
R3021,3039	J00245392	" " " " 3.9kΩ	C3009,3097	K02175151	" " " 150pF
R3007,3009, 3035,3036, 3057,3061, 3063,3078, 3156	J00245472	" " " " 4.7kΩ	C3016	K00175221	" " " 220pF
			C3135	K00175271	" " " 270pF
			C3140,3156, 3157,3159	K12171102	" " 0.001μF
R3002,3003, 3068,3069, 3072,3152	J00245682	" " " " 6.8kΩ	C3001-3003, 3007,3008, 3012,3013, 3015,3035, 3067,3069, 3071,3073, 3075,3077, 3079,3081, 3085-3088, 3090-3092, 3094-3096, 3098-3100, 3102-3104, 3016-3108, 3110-3112, 3114-3116, 3118-3120, 3122,3123, 3124, 3126-3128, 3130,3131, 3136,3149, 3150, 3152-3155, 3158	K13170103	" " 0.01μF
R3017	J00245822	" " " " 8.2kΩ			
R3027,3029, 3043,3044, 3056,3059, 3064,3066, 3067,3083, 3093,3146, 3155,3157, 3158,3174, 3175,3079	J00245103	" " " " 10kΩ			
R3171	J01245103	" " " TJ 10kΩ			
R3019,3031, 3046,3053	J00245123	" " " VJ 12kΩ			
R3016,3034, 3060,3074, 3096,3099, 3103,3107, 3111,3115, 3119,3123, 3127,3131, 3135,3139	J00245153	" " " " 15kΩ			

C3026,3050, 3132,3143, 3139	K13170473	Ceramic	50WV	0.047 μ F			RECEPTACLE
					J3001	P0090132	PI051-04M
					J3005	P0090134	PI051-06M
C3083,3084	K30176101	Dipped Mica	"	100pF	J3002,3003	P0090135	PI051-07M
C3151	K30176151	"	"	150pF	J3007	P0090138	PI051-10M
C3082	K30176331	"	"	330pF	J3004	P0090139	PI051-11M
C3134	K30176511	"	"	510pF	J3006	P0090141	PI051-13M
C3057	K50177102	Mylar	"	0.001 μ F			
C3023	K50177222	"	"	0.0022 μ F			
C3054	K50177472	"	"	0.0047 μ F			
C3037,3038, 3041,3046, 3055	K50177103	"	"	0.01 μ F			
LPF UNIT							
C3031-3033, 3036,3053	K50177223	"	"	0.022 μ F	Symbol No.	Parts No.	Description
C3017	K50177473	"	"	0.047 μ F		C0021280	LPF UNIT ASSEMBLY
C3062,3066	K50177104	"	"	0.1 μ F		C9021090	CONNECTOR A BOARD (W/C)
C3019,3021, 3022,3027, 3028,3039, 3042,3044, 3047,3051, 3052,3056, 3059,3060	K40170105	Electrolytic	"	1 μ F		C9021100	CONNECTOR B BOARD (W/C)
						C9021280	LPF BOARD with components
					PB-2109	F0002109	Printed Circuit Board
					PB-2110	F0002110	" " "
					PB-2128	F0002128	" " "
***** LPF BOARD *****							
C3148	K40170225	"	"	2.2 μ F	PB-2128	F0002128	Printed Circuit Board
C3034,3049, 3142,3146	K40140475	"	25WV	4.7 μ F			
C3020,3040, 3045,3058, 3145,3147	K40120106	"	16WV	10 μ F	D4001, 4008-4012	G2015550	Si 1S1555
C3024,3029, 3030,3144	K40120226	"	"	22 μ F	D4002-4007	G2090038	Schottky barrier 1SS16
C3018,3025, 3048	K40120336	"	"	33 μ F	D4013,4014	G2090001	Si 10D1
C3030,3141	K40100107	"	10WV	100 μ F			RESISTOR
C3061, 3063-3065	K40120227	"	16WV	220 μ F	R4002	J00245470	Carbon film 1/4W VJ 47 Ω
C3043	K70127475	Tantalum	10WV	10 μ F	R4003	J00245471	" " " " 470 Ω
					R4001	J00245107	" " " " 1k Ω
POTENTIOMETER							
					VR4001	J50710203	V10K-8-1-2 20k Ω
TRIMMER CAPACITOR				CAPACITOR			
TC3001-3004, 3012	K91000013	ECV1ZW-20x32, 20pF			C4034-4040, 4062-4073	K13170103	Ceramic 50WV 0.01 μ F
TC3005-3011	K91000016	ECV1ZW-50x32, 50pF			C4001, 4041-4050, 4074-4081	K13170473	" " 0.047 μ F
INDUCTOR							
L3005	L1190023	FL5H-220K		22 μ H	C4014,4024, 4030	K30279064	Dipped Mica 50WV 10pF
L3001-3004, 3006,3007	L1190016	FL5H-101K		100 μ H	C4025,4031	K30279016	" " " 12pF
L3008	L1190017	FL5H-102K		1mH	C4022	K30279065	" " " 15pF
					C4018	K30279118	" " " 18pF
					C4021	K30279100	" " " 20pF
					C4010,4028	K30279069	" " " 33pF
					C4012	K30279115	" " " 36pF
TRANSFORMER							
T3001	L0020209	4:1			C4003	K30279070	" " " 39pF
T3002, 3004-3012	L0020628				C4016	K30279116	" " " 51pF
T3003	L0020787				C4027	K30279072	" " " 68pF
					C4009,4032	K30279114	" " " 75pF
					C4006	K30279073	" " " 82pF
					C4020	K30279074	" " " 100pF
RELAY							
RL3001	M1190002	FBR211AD012-M			C4026	K30279111	" " " 110pF
					C4015,4029	K30279077	" " " 150pF
					C4019	K30279079	" " " 180pF
					C4023	K30279081	" " " 220pF

C4004	K30279082	Dipped Mica	500WV	240pF	C4305	K02179013	Ceramic	50WV NPO	33pF
C4008,4017	K30279085	"	"	330pF					
C4013	K30279086	"	"	360pF					VARIABLE CAPACITOR
C4002,4033	K30279089	"	"	510pF	VC4301	K90000024			C521R122
C4007,4011	K30279113	"	"	680pF					
C4005	K30279095	"	"	1200pF					TRIMMER CAPACITOR
C4051-4061	K21170002	Feed thru	50WV	1000pF	TC4301	K90000001			TSN-100D15, 15pF
									INDUCTOR
		TRIMMER CAPACITOR			L4301	L0020268			
TC1001	K91000019	ECV1ZW-10x40,		10pF					PILOT LAMP
					PL4301,4302	Q1000035			BQ044-22836A
									FET & TRANSISTOR
		INDUCTOR			Q4302	G3090035	FET		2SK19TM-GR
L4001	L0020615				Q4301,4303	G3318150Y	TR		2SC1815Y
L4002	L0020616								
L4003	L0020617								DIODE
L4004	L0020618				D4301	G2022360	Varactor		1S2236
L4005	L0020619								
L4006	L0020620								
L4007	L0020621								
L4008	L0020622								RESISTOR
L4009	L0020623				R4309,4311	J00245101	Carbon film	1/4W VJ	100Ω
L4010	L0020624				R4307	J00245221	"	"	220Ω
					R4305,4308	J00245222	"	"	2.2kΩ
		TRANSFORMER			R4302	J00245332	"	"	3.3kΩ
T4001	L0020301A				R4301	J00245103	"	"	10kΩ
					R4303	J00245183	"	"	18kΩ
		RELAY			R4304	J00245223	"	"	22kΩ
RL4001-4011	M1190024	FBR311D012			R4306,4310	J00245104	"	"	100kΩ
***** CONNECTOR A BOARD *****									
PB-2109	F0002109	Printed Circuit Board							CAPACITOR
		CONNECTOR			C4327	K02179001	Ceramic	50WV NPO	1pF
J4002	P0090150	PI021-06M			C4307	K02173080	"	"	8pF
					C4314	K02179013	"	"	33pF
					C4308,4318	K02175390	"	"	39pF
					C4311	K02179023	"	"	180pF
PB-2110	F0002110	Printed Circuit Board			C4321,4323	K00175471	"	"	SL 470pF
		CONNECTOR			C4309,4310,	K13170103	"	"	0.01μF
J4001	P0090149	PI021-05M			4312,4315,				
					4319,4320,				
					4324,4326				
		CAPACITOR			C4313	K30176431	Dipped Mica	"	430pF
C4074-4079	K13170473	Ceramic	50WV	0.047μF	C4302,4322	K30209001	"	"	1000pF
					C4325	K70167334	Tantalum	10WV	0.33μF
	Q5000011	Wrapping terminal C							
									TRIMMER CAPACITOR
					TC4302	K91000016			ECV-1ZW 50x40, 50pF
VFO UNIT									
Symbol No.	Parts No.	Description			L4304,4305	L1190007	FL4H-1R8M, 1.8μH		
		VFO assembly (3540)			L4303,4306	L1190001	250μH		
		VFO chassis			L4302	L1190040	S4 1mH		
		VFO board							
									RECEPTACLE
		***** VFO CHASSIS *****			J4301	P0090133	PI021-05M		
		CAPACITOR							
C4301	K06173080	Ceramic	50WV	UJ 8pF					
C4303	K06175120	"	"	" 12pF					
C4304	K02175180	"	"	NPO 18pF					

COUNTER UNIT (3540)			C4417,4419, 4421, 4426-4429	K13170103	Ceramic	50WV NPO	0.01μF	
Symbol No.	Parts No.	Description						
	C0020861A	COUNTER UNIT ASSEMBLY						
	C9020861A	COUNTER MAIN UNIT	C4423	K50177103	Mylar	"	0.01μF	
	F0002086A	COUNTER MAIN BOARD	C4410,4418	K40120106	Electrolytic	16WV	10μF	
			C4416	K40129001	"	16WV	330μF	
			C4413	K40109004	"	10WV	470μF	
***** COUNTER MAIN BOARD *****			C4422 (NOISE LIMITTER)	K71137685	Tantalum	20WV	6.8μF	
		IC, FET & TRANSISTOR						
Q4412	G1090249	IC MSM9520RS						
Q4420	G1090079	" μPA54H						
Q4401	G4800730	FET 3SK73GR					TRIMMER CAPACITOR	
Q4406-4411, 4413-4419	G3109520L	TR 2SA952L	TC4401	K91000030			ECV1ZW 40x53, 40pF	
Q4403	G3316740	" 2SC1674L					INDUCTOR	
Q4404	G3318150G	" 2SC1815GR	L4401	L2030068	SN Coil		2mH	
							RECEPTACLE	
		DIODE	J4401	P0090051			5048-06A	
D4401-4413	G20155550	Si 1S1555	J4402	P0090054			5048-07A	
			J4403	P0090037			5048-08A	
		CRYSTAL						
X4401	H0102272	HC-18/U 6.5536MHz					PLUG	
			P4403	P1090186			3021-03A	
		RESISTOR						
R4412	J00245100	Carbon film 1/4W VJ 10Ω	***** DISPLAY BOARD *****					
R4431,4434, 4437,4440, 4443,4446, 4449	J00245330	" " " " 33Ω		C002098A			PCB with components	
				F0002098A			Printed Circuit Board	
R4450	J00245560	" " " " 56Ω	D4501-4506	G2090069			DISPLAY LED	
R4401	J01245560	" " " TJ 56Ω					HP5082-7623	
R4408,4418, 4420,4422, 4424,4426, 4428	J00245101	" " " VJ 100Ω					PLUG	
R4407,4410, 4411	J00245221	" " " " 220Ω	P4501				5047-06	
R4417,4419, 4421,4423, 4425,4427, 4430,4433, 4436,4439, 4442,4445, 4448	J01245102	" " " TJ 1kΩ	P4502				5047-08	
R4429,4432, 4435,4438, 4441,4444, 4447	J00245152	" " " VJ 1.5kΩ						
R4402,4415	J00245562	" " " " 5.6kΩ	AVR UNIT					
R4413	J00245103	" " " " 10kΩ	Symbol No.	Parts No.	Description			
R4409	J00245473	" " " " 47kΩ		C0020990	PCB with Components			
R4414,4416	J01245104	" " " " 100kΩ		F0002099	Printed Circuit Board			
							IC & TRANSISTOR	
			Q4602	G1090070	IC		μPC14308	
			Q4601	G3408800	TR		2SD880Y	
							DIODE	
			D4601	G2090001	Si		10D1	
							RESISTOR	
			R4602	J30356100	Wire wound	3W	10Ω	
		CAPACITOR	R4601	J00245330	Carbon film	1/4W	33Ω	
C4424	K02179008	Ceramic 50WV NPO 20pF	R4606	J00245682	" " "		6.8kΩ	
C4425	K02175470	" " " " 47pF	R4603	J00245822	" " "		8.2kΩ	
C4420	K02175101	" " " " 100pF	R4605	J00245123	" " "		12kΩ	
C4401,4404	K13170102	" " " " 0.001μF	R4604	J00245153	" " "		15kΩ	
C4402,4405, 4408,4409, 4411,4412, 4414,4415,	K13170103	" " " " 0.01μF					POTENTIOMETER	
			VR4601	J50710502	V10K8-1-2		5kΩB	

VR B UNIT				Symbol No.	Parts No.	Description	C4201,4203, 4207,4208, 4212,4214, 4217,4219, 4221,4223, 4226,4230, 4231	K13170473	Ceramic	50WV	0.047μF
Symbol No.	Parts No.	Description									
	C0021031	PCB with Components									
	F0002103	Printed Circuit Board									
		POTENTIOMETER									
VR5101 (DELAY)	J51734474	CR19D	470kΩ								
				C4204,4209	K23170005	" chip "					0.1μF
				C4237	K14179003	" "					0.1μF
				C4235	K30279073	Dipped mica	500WV				82pF
				C4243	K	" "					330pF
				C4228	K30279092	" "					750pF
				C4232-4234	K30279051	" "					1000pF
				C4227,4229	K30279118	" "					5000pF
				C4238	K40169003	Electrolytic	35WV				330μF
				C4222	K70127335	Tantalum	16WV				3.3μF
				C4213,4215, 4218,4220, 4224,4225, 4242	K70127106	" "					10μF
		IC & TRANSISTOR									
Q4206	G1090070	IC	μPC14308								
Q4201	G3315890	TR	2SC1589	C4240,4041	K50177683	Mylar	50WV				0.068μF
Q4204,4205	G3322900	"	2SC2290	C4239	K50177104	" "					0.1μF
Q4202,4203	G3323950	"	2SC2395								
Q4207	G3402350Y	"	2SD235Y								
											INDUCTOR
				L4201-4204	L1020035						
		DIODE		L4206	L0020395A						
D4201	G2090021	Zener	YZ-033	L4205,4207	L1020015						
D4202-4205	G2090002	Si	10D10								
											TRANSFORMER
				T4201	L0020289A	INPUT					
		RESISTOR		T4202	L0020631B	DRIVER					
R4209,4211, 4216,4218	J10276159	Carbon composition	1/2W 1.5Ω	T4203	L0020632	OUTPUT					
R4206	J10276479	" " "	4.7Ω								MOTOR
R4207,4219, 4220	J10276180	" " "	18Ω			M2190004					MDN-7R1
R4212,4213	J10276240	" " "	24Ω			R7056970					RADIAL FAN
R4202	J00245330	Carbon film	1/4W VJ 33Ω								
R4210	J10276390	Carbon composition	1/2W 39Ω								PLUG
R4217,4221, 4222	J20335390	Metallic film	2W 39Ω	P4202	P1090187	PI051-02F					
R4223	J20335680	" " "	68Ω	P4203	P1090188	PI051-03F					
R4214,4215	J10276121	Carbon composition	1/2W 120Ω			Q5000011					Wrapping terminal C
R4201	J00245121	Carbon film	1/4W VJ 120Ω								
R4203,4204	J10276331	Carbon composition	1/2W 330Ω								
R4224	J00245681	Carbon film	1/4W VJ 680Ω								
R4208	J10276102	Carbon composition	1/2W 1kΩ								
R4205	J01245152	Carbon film	1/4W TJ 1.5kΩ								
											LED UNIT
				Symbol No.	Parts No.	Description					
					C0021110A	PCB with Components					
					F0002111A	Printed Circuit Board					
		THERMISTOR									LED
TH4201	G9090009		32D27	D5201-5204	G2090134						TLY-205
		POTENTIOMETER									RESISTOR
VR4201	J51727222	CR19R	2.2kΩB	R5201	J01245561	Carbon film	1/4W TJ				560Ω
		CAPACITOR									
C4205,4206	K10179017	Ceramic	50WV 0.0047μF								
C4202	K10176103	"	" 0.01μF								
C4210,4211, 4216,4236	K10177103	"	" 0.01μF								

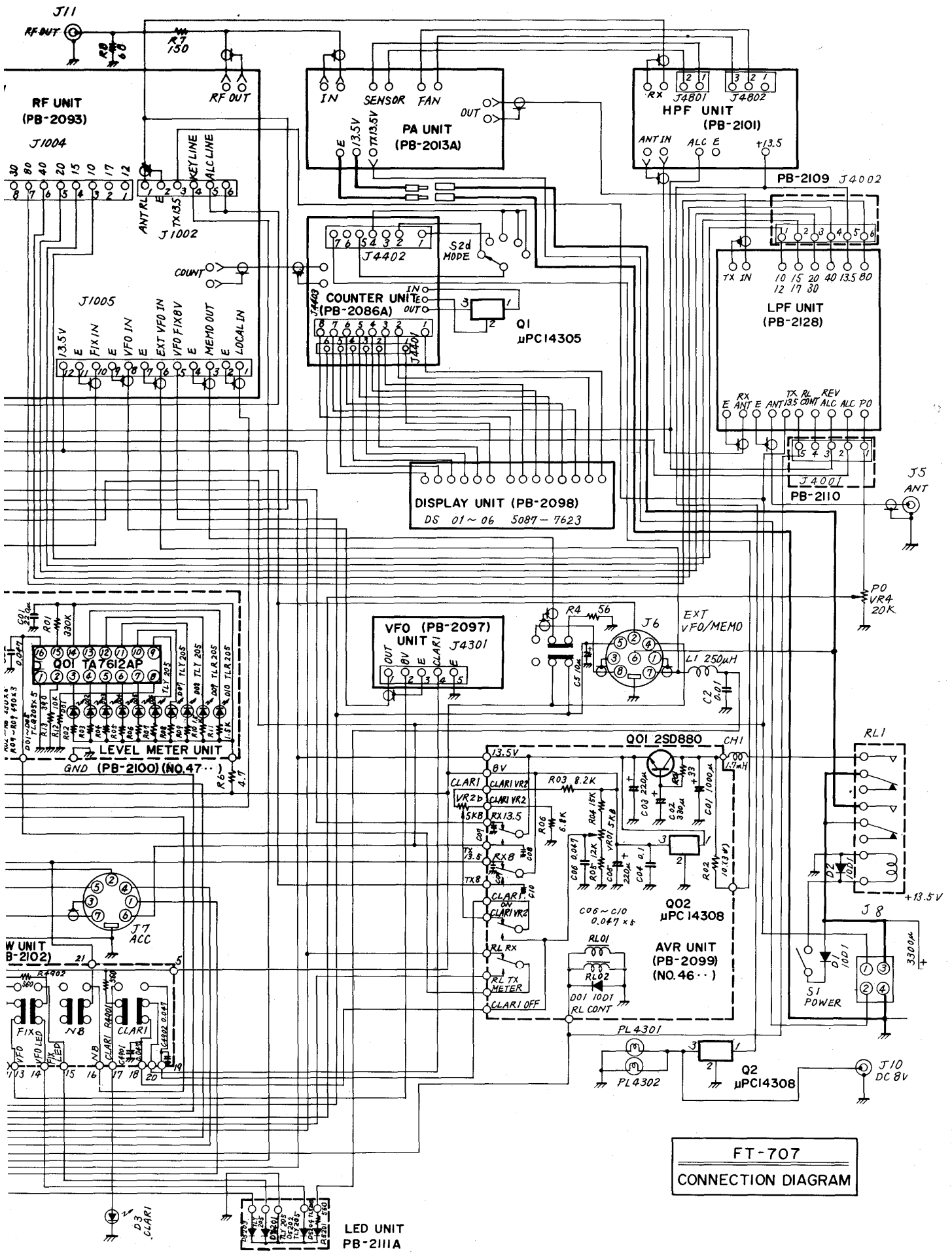

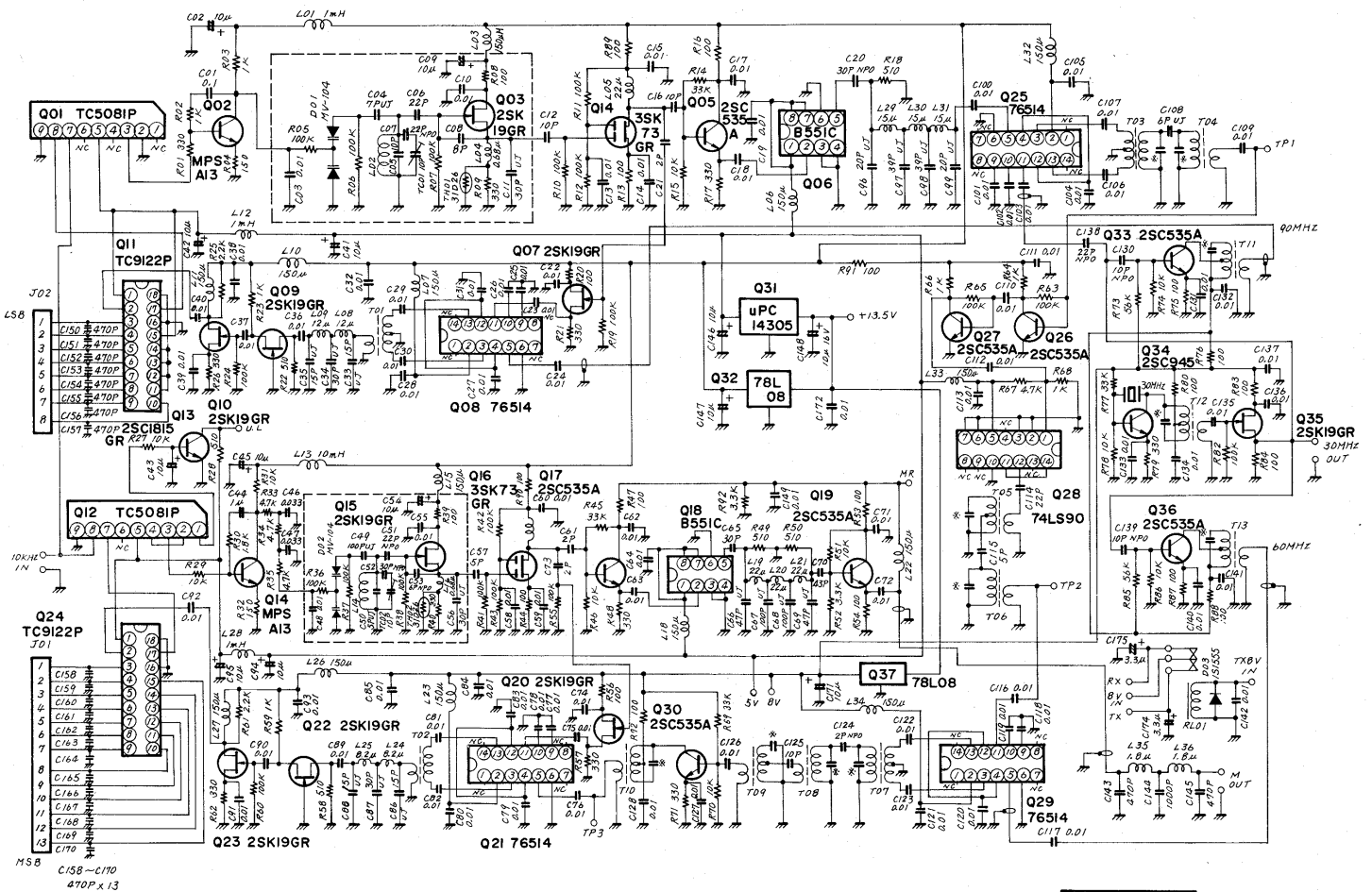

MSB
C158 - C170
470P x 13

PB-2122(NO.20..)

FV-707 DM
PLL UNIT

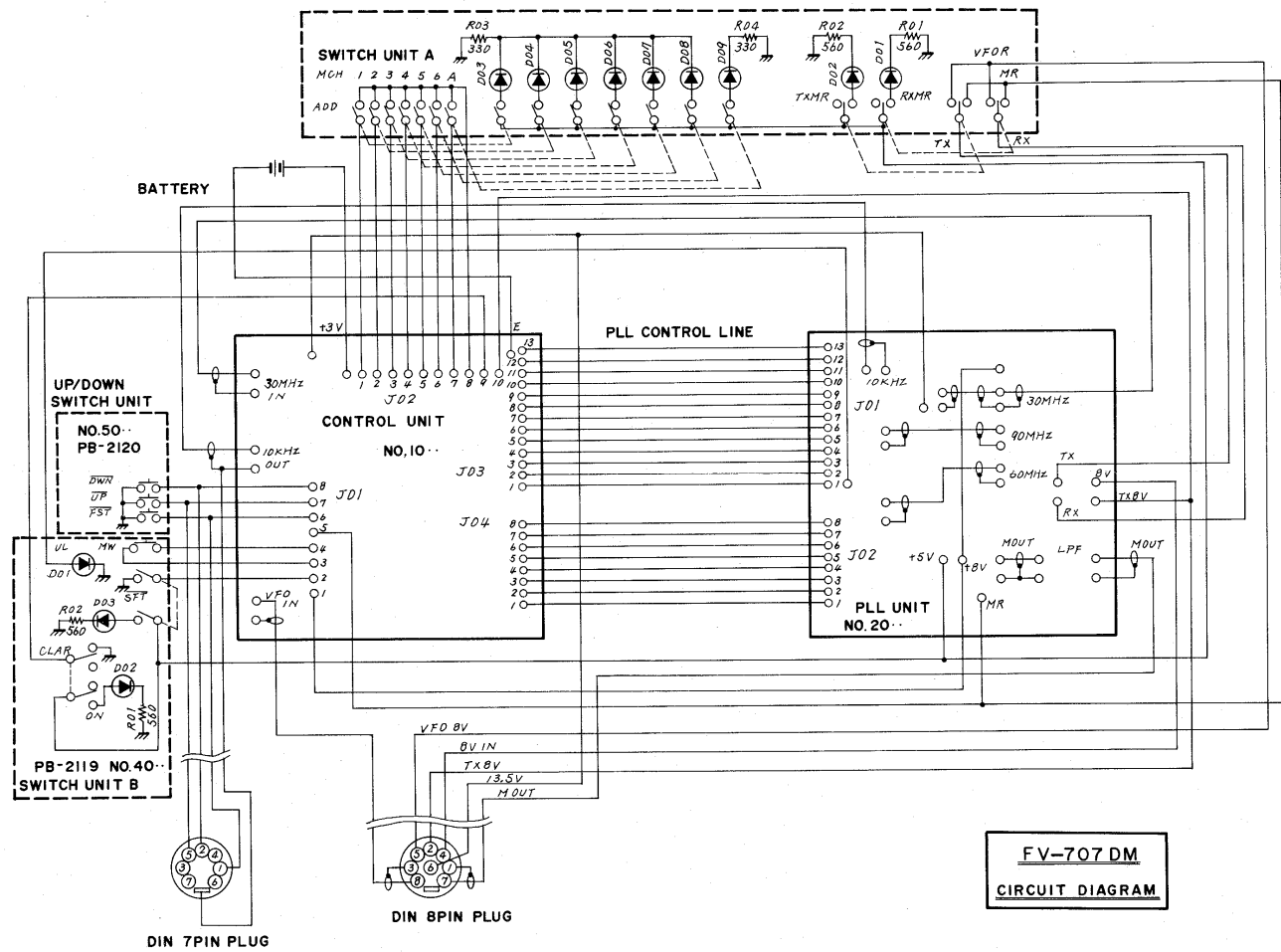

FV-707 DM
CIRCUIT DIAGRAM

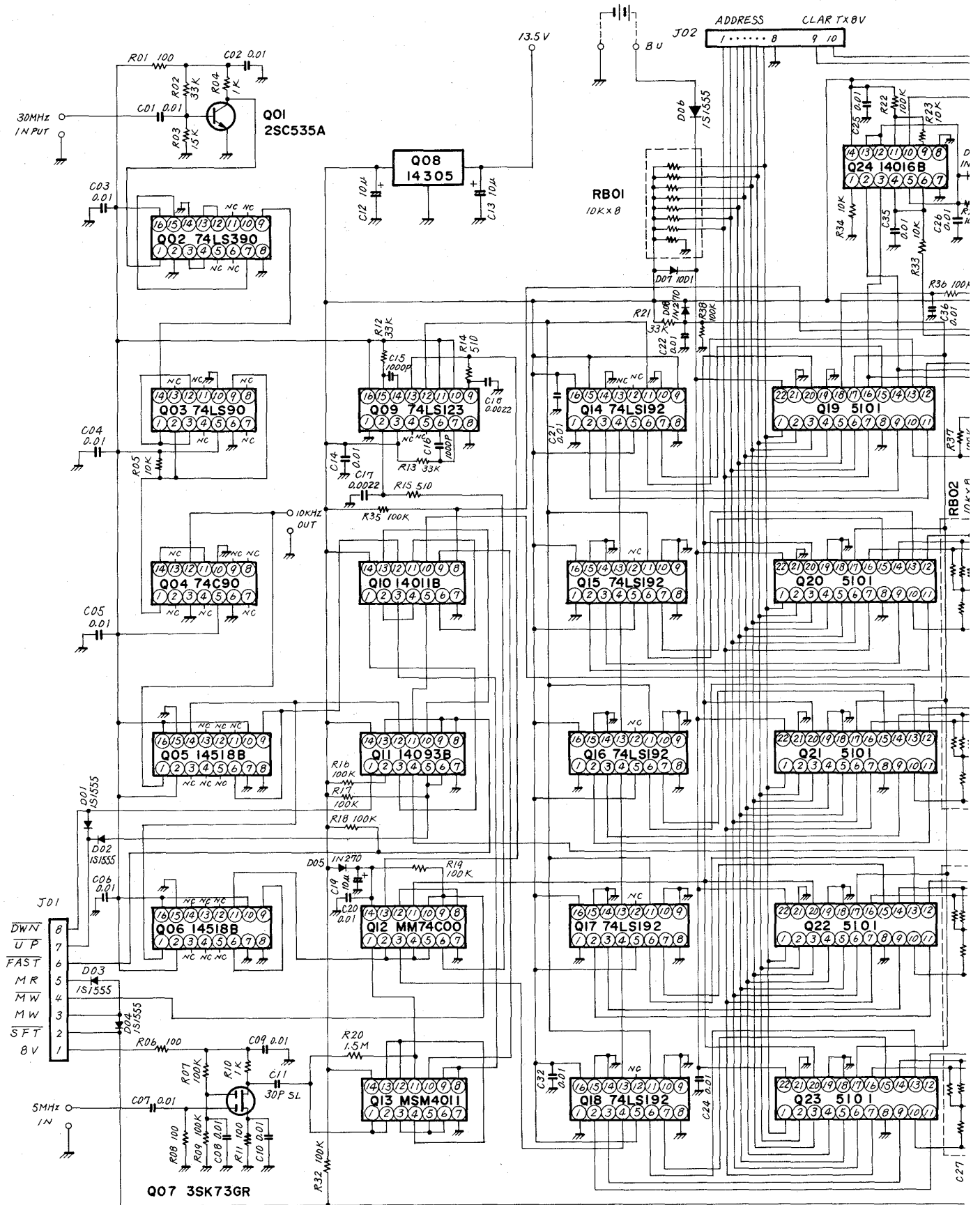

x8V

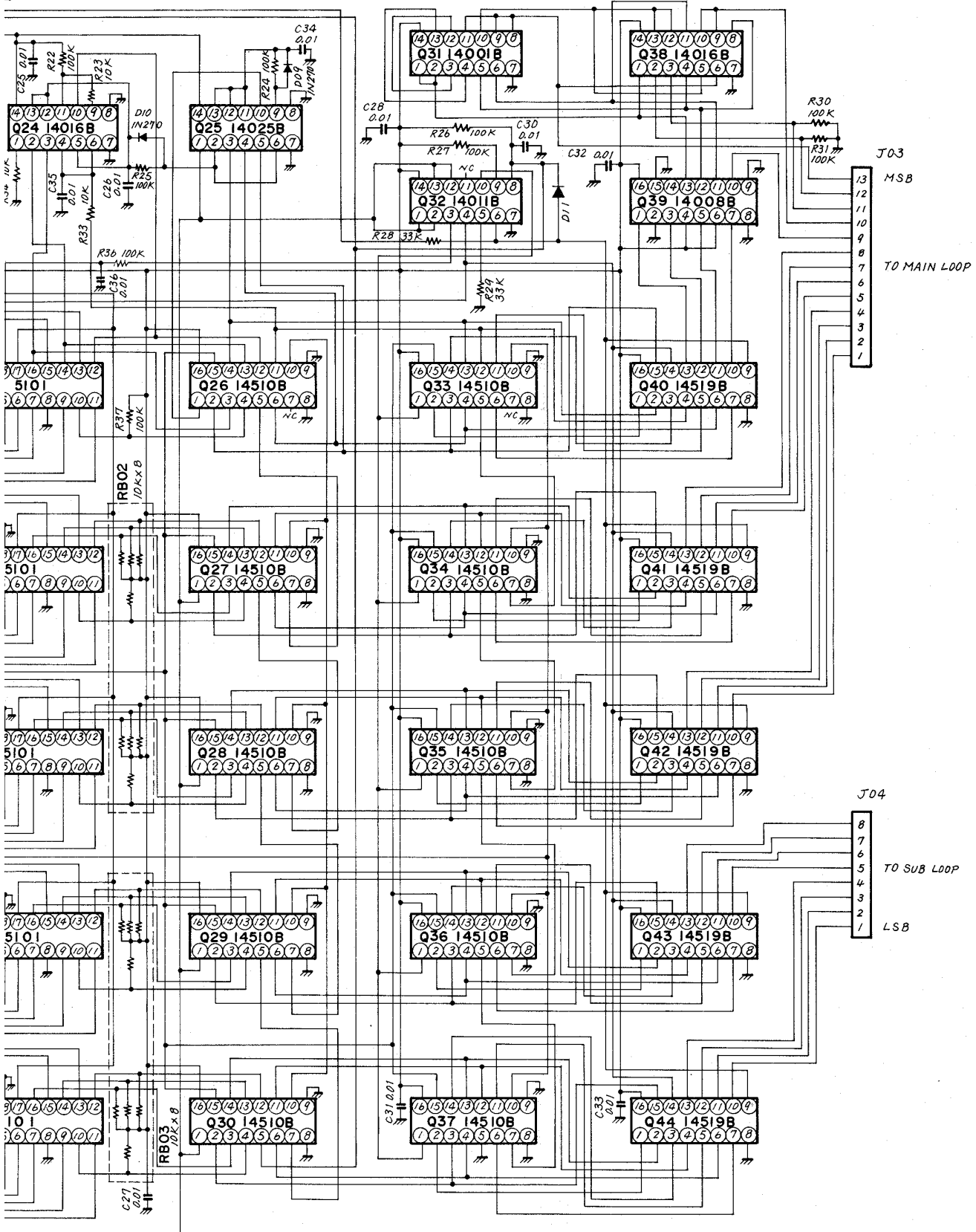

PB-2123 (NO.10..)

FV-707 DM
CONTROL UNIT

